



Japanese Technology since 1912

## AGA-AGC

Data Book 50Hz



	Page
<b>- SPECIFICATIONS</b> <sup>①</sup>	<b>200</b>
PERFORMANCE RANGE and SELECTION CHART	201
TYPE KEY and CURVE SPECIFICATIONS	202
PERFORMANCE CURVE AGA 0.60	203
PERFORMANCE CURVE AGA 0.75	204
PERFORMANCE CURVE AGA 1.00	205
PERFORMANCE CURVE AGA 1.50	206
PERFORMANCE CURVE AGA 2.00	207
PERFORMANCE CURVE AGA 3.00	208
PERFORMANCE CURVE AGC 1.50	209
PERFORMANCE CURVE AGC 2.00	210
PERFORMANCE CURVE AGC 3.00	211
<b>- CONSTRUCTIONS</b>	<b>300</b>
SECTIONAL VIEW	300
MECHANICAL SEAL	301
BEARINGS	301
<b>- DIMENSIONS and WEIGHT</b>	<b>400</b>
PUMP	400
PACKING	401
<b>- TECHNICAL DATA</b>	<b>500</b>
MOTOR DATA	500
NOISE DATA	500

① click INDEX to jump CORRESPONDING SECTION

② click  to go back to INDEX

## SPECIFICATION

50Hz

Rev.O

PUMP		
Liquid Handled	Type of liquid	Clean water
	Temperature [°C]	min. +5 max. +45
Maximum working pressure	[MPa]	0.6 (AGA 0.60-0.75-1.00) 1.0 (AGA 1.50-2.00-3.00; all AGC)
Maximum suction depth	[m]	8
Construction	Impeller	Closed centrifugal type
	Shaft seal type	Mechanical seal
	Bearing	Sealed ball bearing
Pipe Connection	Suction	G 1 (AGA 0.60-0.75-1.00) UNI ISO 228
		G 1½ (AGA 1.50-2.00-3.00; all AGC) UNI ISO 228
	Discharge	G 1 UNI ISO 228
Material	Casing	Cast iron
	Impeller	PPE+PS glass fibre reinforced (AGA 0.60-0.75-1.00)
		Brass (AGA 1.50-2.00-3.00; all AGC)
	Shaft seal	Ceramic/Carbon/NBR
	Casing cover	AISI 304 (AGA 0.60-0.75-1.00)
		Cast iron built-in on the motor bracket (AGA 1.50-2.00-3.00; all AGC)
	Shaft	AISI 303 (wet extension)
	Bracket	Aluminium (AGA 0.60-0.75-1.00)
Cast iron (AGA 1.50-2.00-3.00; all AGC)		
Ejector	PPE+PS glass fibre reinforced	
Diffuser	PPE+PS glass fibre reinforced	
Applicable standard of test		ISO 9906:2012 – Grade 3B

MOTOR		
Type	Electric - TEFC	
	Single Phase	Three Phase
Efficiency level (Reg. 1781/2019)	IE2	IE3
No. of Poles	2	
Rotation speed [min <sup>-1</sup> ]	≈ 2800	
Insulation Class	F	
Protection degree (CEI EN 60034-5)	IP 44	
Power rating	[kW]	0.44÷1.5
	[HP]	0.6÷2
Frequency [Hz]	50	
Voltage [V]	230 ±10%	230/400 ±10%
Capacitor	Built in	-
Over load protection	Built in	Provided by the user
Casing material	Aluminium	
Base material / Motor support	Plastic foot /Cast iron	
Dimensions of cable entry	PG11 - PG13.5 – M16x1.5 – M20x1.5 (see dimensions page 400)	

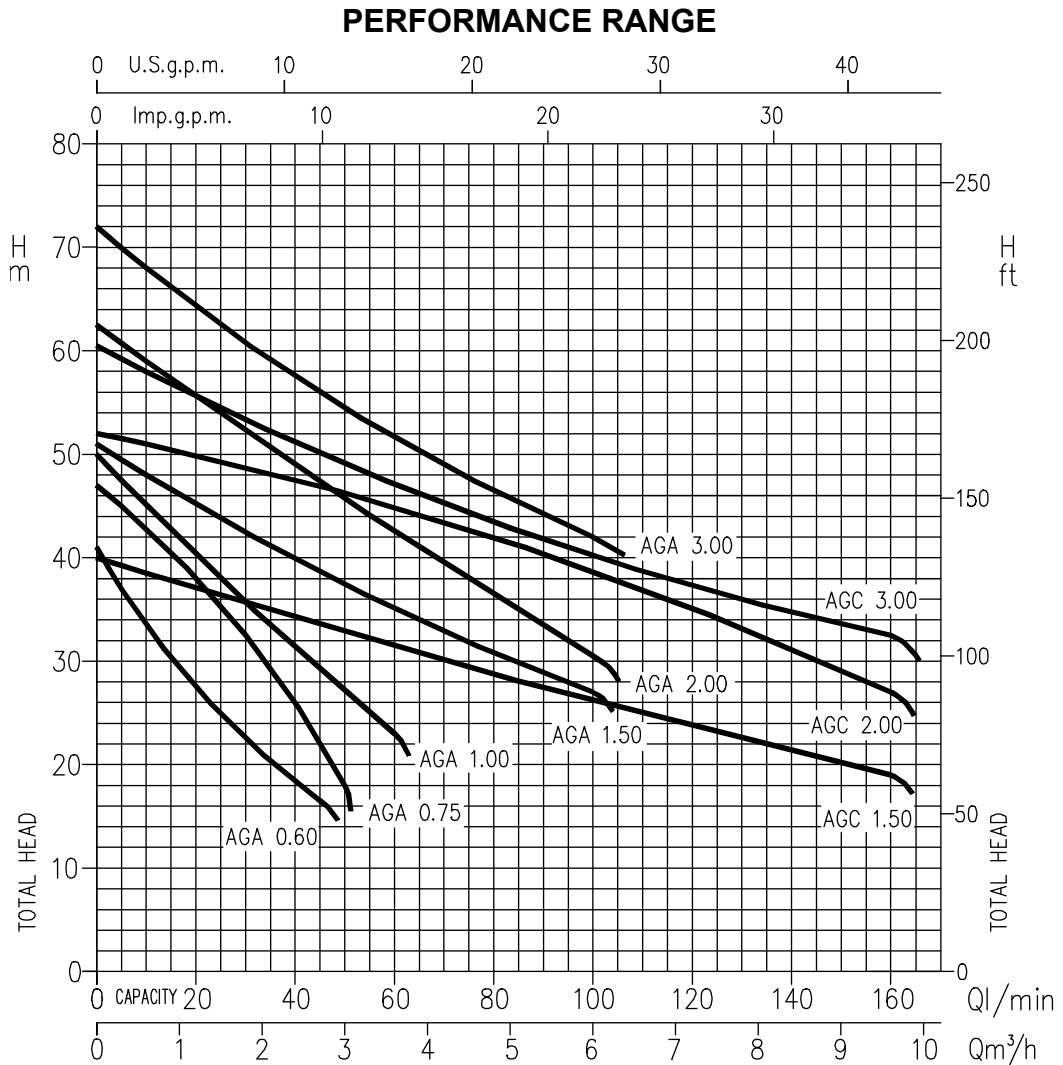

**SELECTION CHART**

Type pumps		Q=Capacity												
		l/min m³/h	0	5	10	20	30	45	50	60	80	100	130	160
Single Phase	Three Phase		0	0,3	0,6	1,2	1,8	2,7	3,0	3,6	4,8	6	7,8	9,6
		H=Total manometric head in meters												
AGA 0.60 M	AGA 0.60 T	41.5	37	33.4	27.1	22	16.5	-	-	-	-	-	-	-
AGA 0.75 M	AGA 0.75 T	47	45	42.8	37.9	32	21.9	18	-	-	-	-	-	-
AGA 1.00 M	AGA 1.00 T	50	47,5	45	40.3	35.7	29.1	27	23	-	-	-	-	-
AGA 1.50 M	AGA 1.50 T	51	-	48	45.1	42.4	38.6	37.4	35.1	30.8	27	-	-	-
AGA 2.00 M	AGA 2.00 T	62.5	-	59	55.6	52.2	47.3	45.7	42.5	36.4	30.5	-	-	-
-	AGA 3.00 T	72	-	68	64.3	60.8	55.9	54.4	51.6	46.4	42	-	-	-
AGC 1.50 M	AGC 1.50 T	40	-	38.5	37	35.6	33.5	32.7	31.4	28.7	26.1	22.4	19	-
AGC 2.00 M	AGC 2.00 T	52	-	51	49.9	48.8	46.9	46.3	44.9	42	38.7	33.2	27	-

**TYPE KEY and CURVE SPECIFICATIONS**

50Hz

Rev.O

**TYPE KEY**

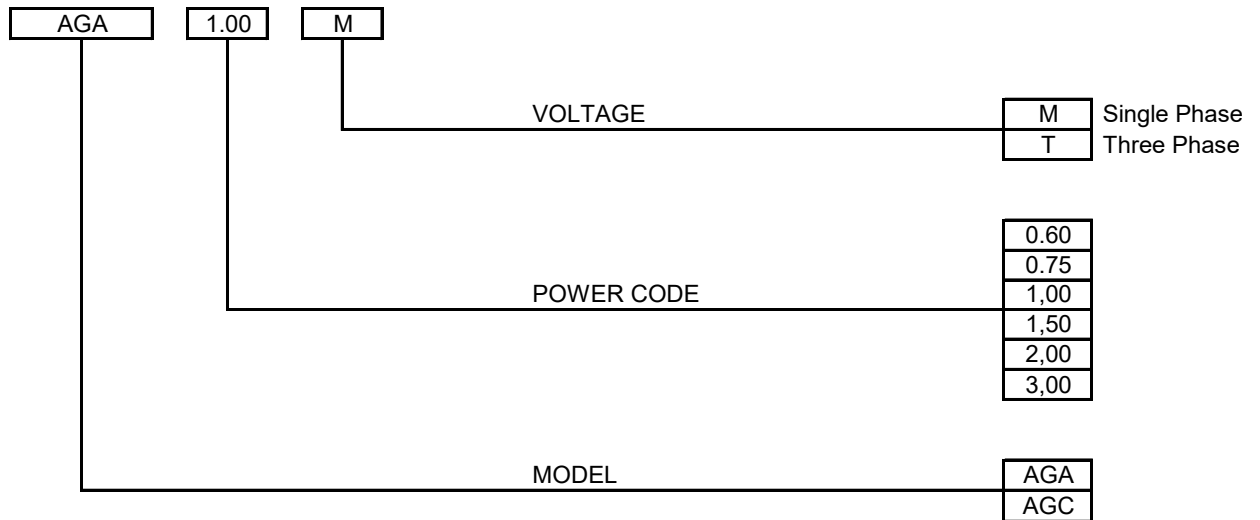

**PERFORMANCE CURVE SPECIFICATIONS**

The specifications below qualify the curves shown on the following pages.

Tolerances according to ISO 9906:2012 – Grade 3B

The curves refer to effective speed of asynchronous motors at 50 Hz, 2 poles.

Measurements were carried out with clean water at 20°C of temperature and with a kinematic viscosity of  $\nu = 1 \text{ mm}^2/\text{s}$  (1 cSt)

In order to avoid the risk of over-heating, the pumps should not be used at a flow rate below 10% of best efficiency point.

Symbols explanation:

- Q = volume flow rate
- H = total head
- $P_2$  = pump power input (shaft power)
- $\eta$  = pump efficiency

AGA 0.60 - Impeller diameter = 130 mm

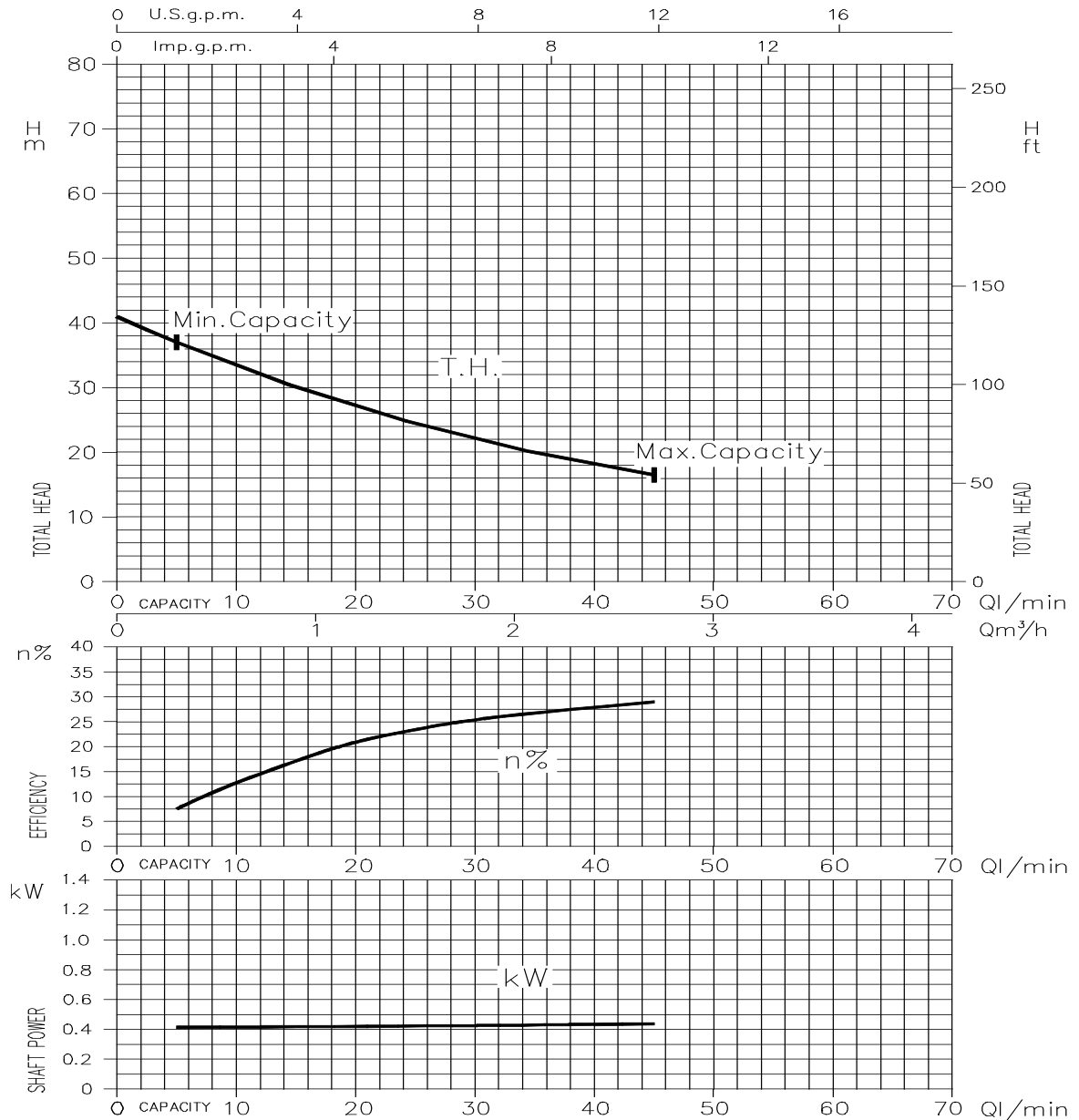

Rotation speed  $\approx 2800 \text{ min}^{-1}$   
 Test standard: ISO 9906:2012 – Grade 3B

AGA 0.75 - Impeller diameter = 130 mm

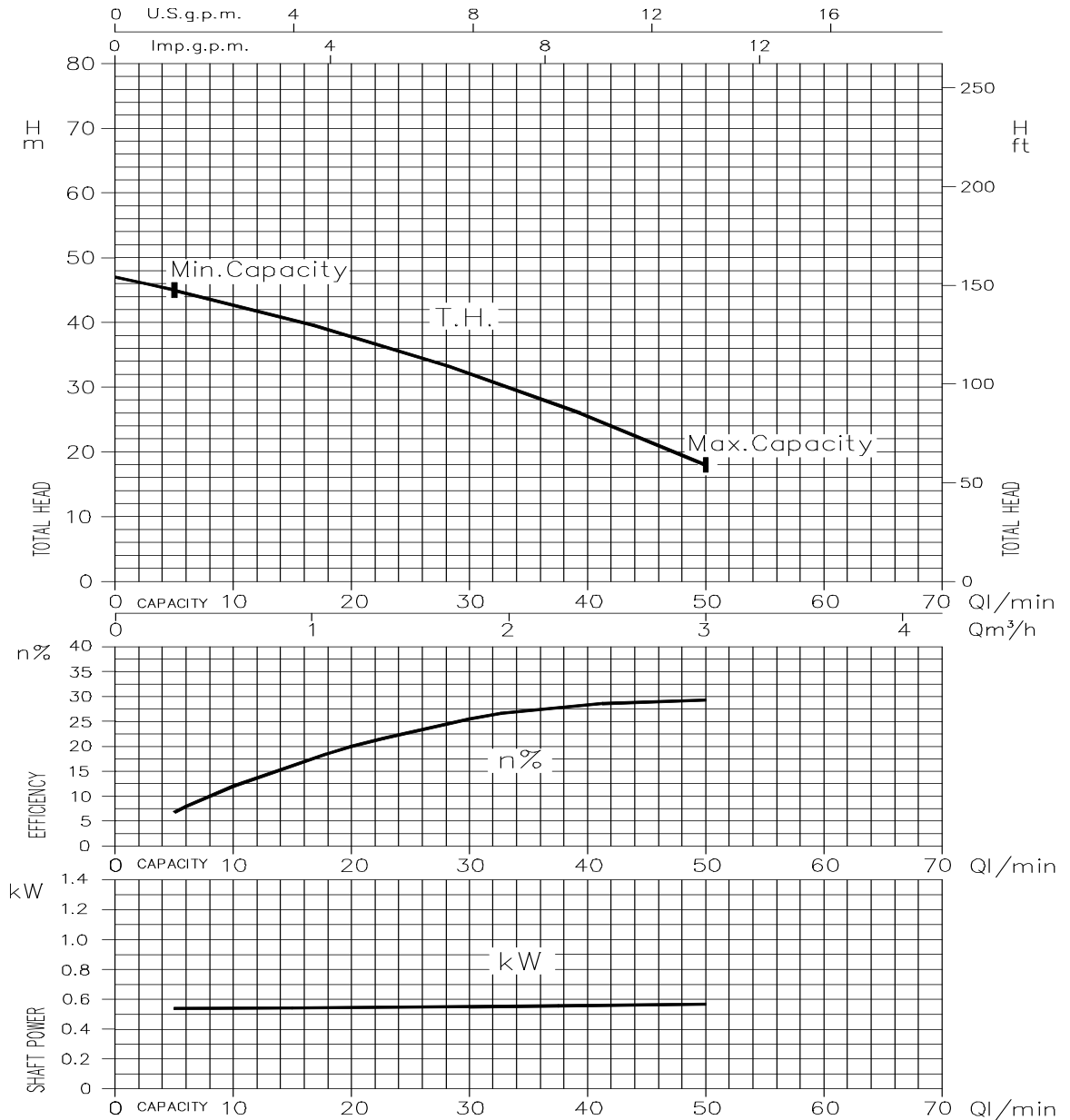

Rotation speed  $\approx 2800 \text{ min}^{-1}$   
 Test standard: ISO 9906:2012 – Grade 3B

AGA 1.00 - Impeller diameter = 130 mm

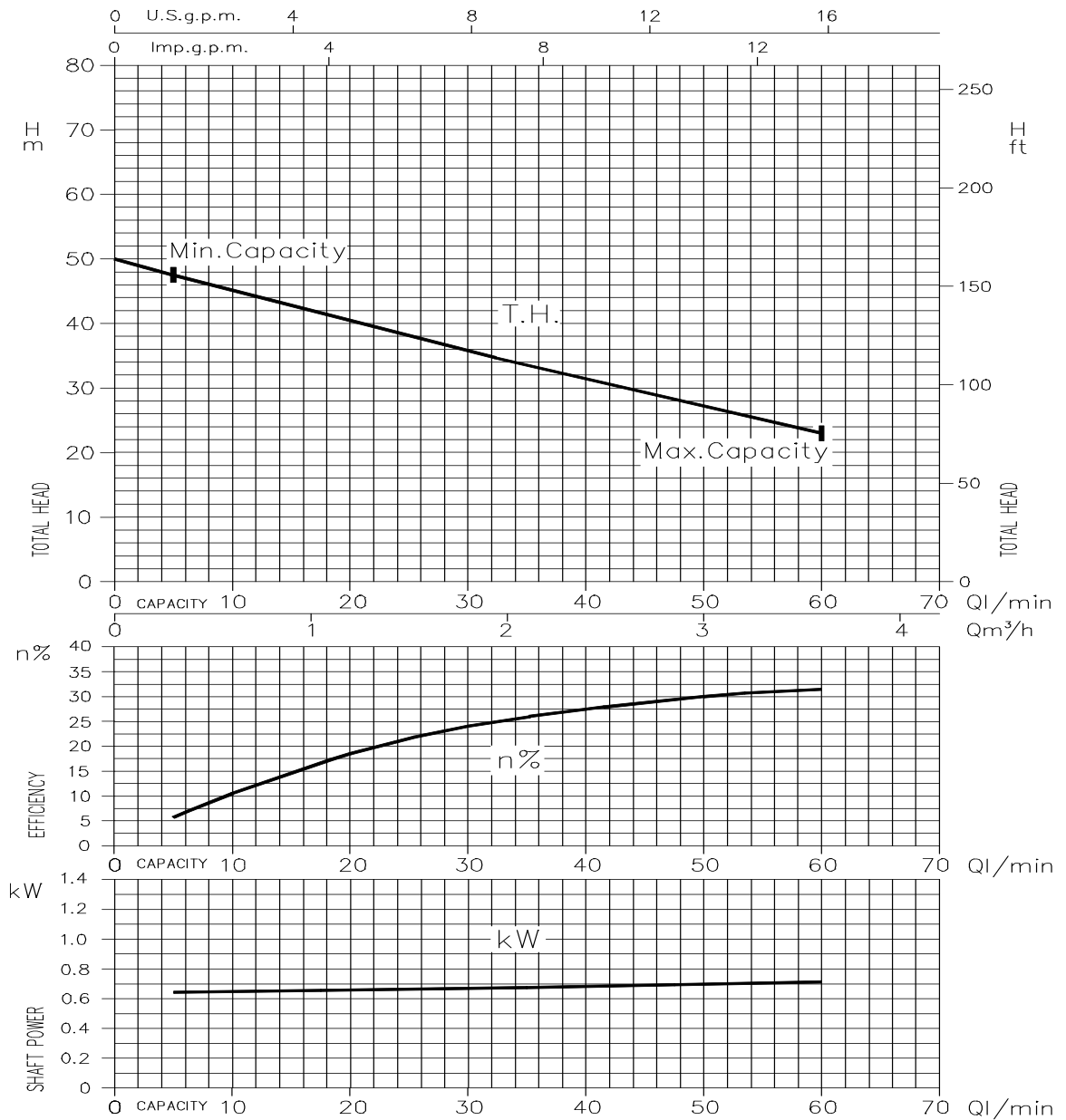

Rotation speed  $\approx 2800 \text{ min}^{-1}$   
 Test standard: ISO 9906:2012 – Grade 3B



AGA 1.50 - Impeller diameter = 143 mm

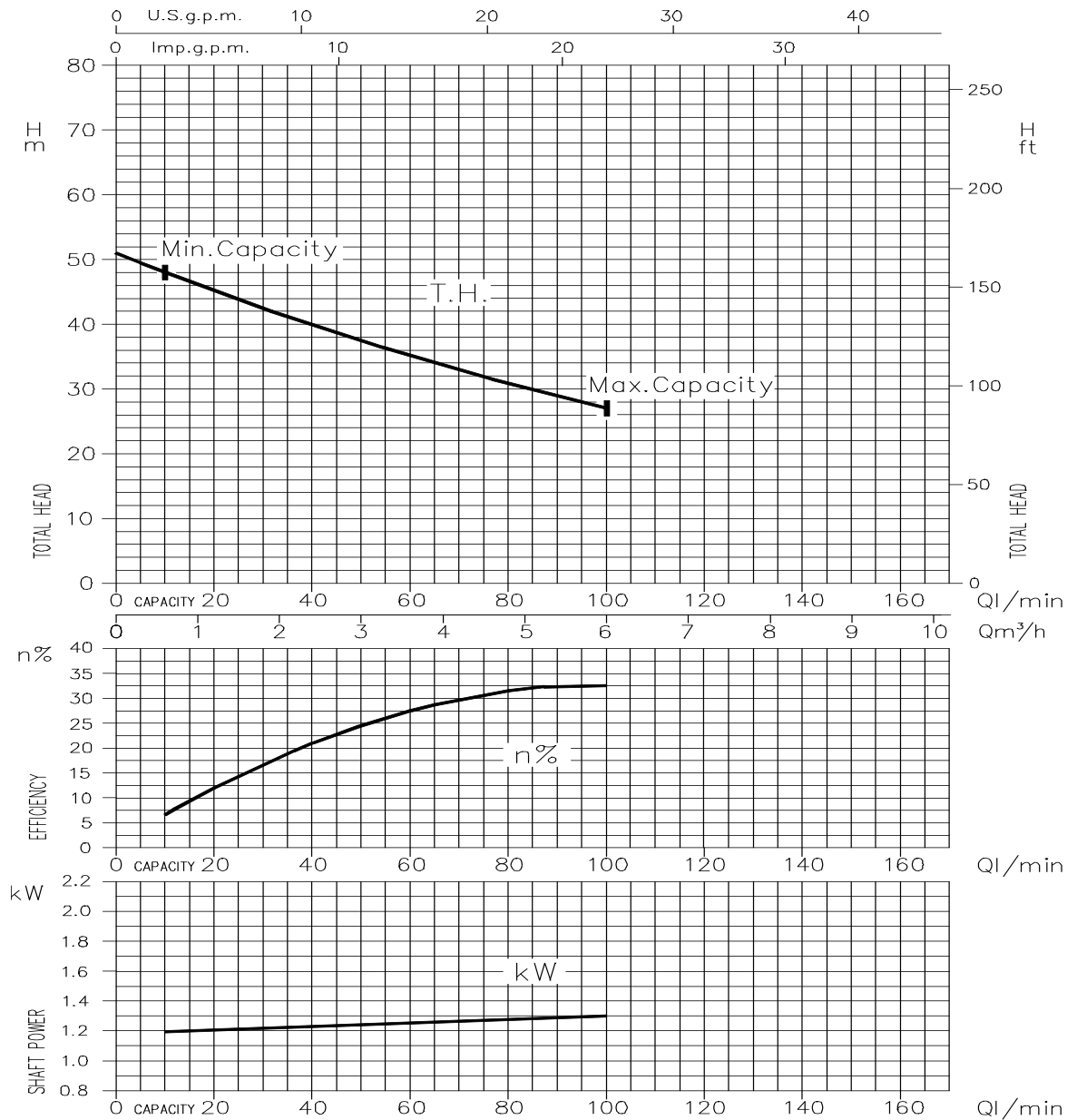

Rotation speed  $\approx 2850 \text{ min}^{-1}$   
 Test standard: ISO 9906:2012 – Grade 3B

AGA 2.00 - Impeller diameter = 157 mm

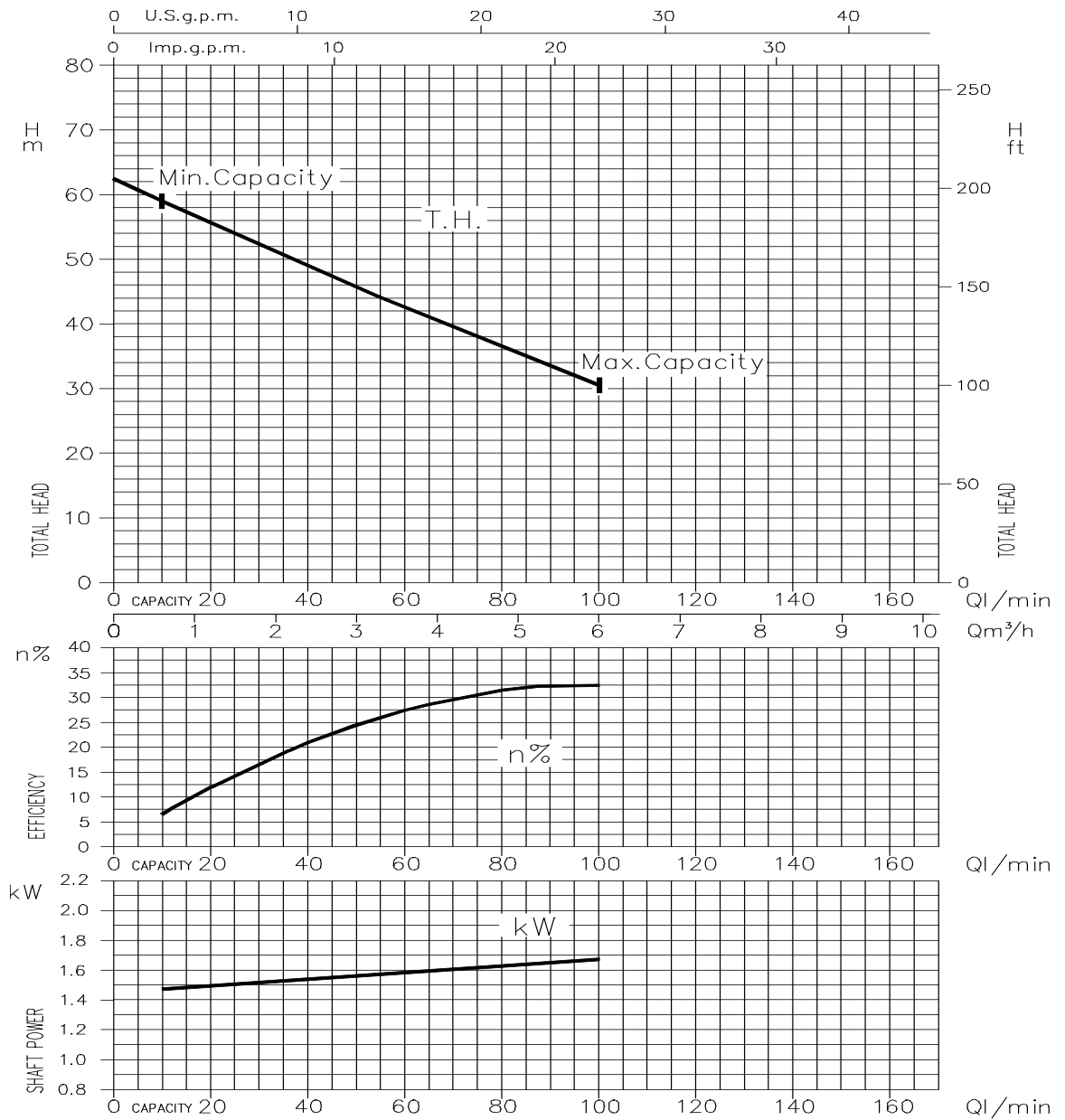

Rotation speed  $\approx 2850 \text{ min}^{-1}$   
 Test standard: ISO 9906:2012 – Grade 3B

AGA 3.00 - Impeller diameter = 164 mm

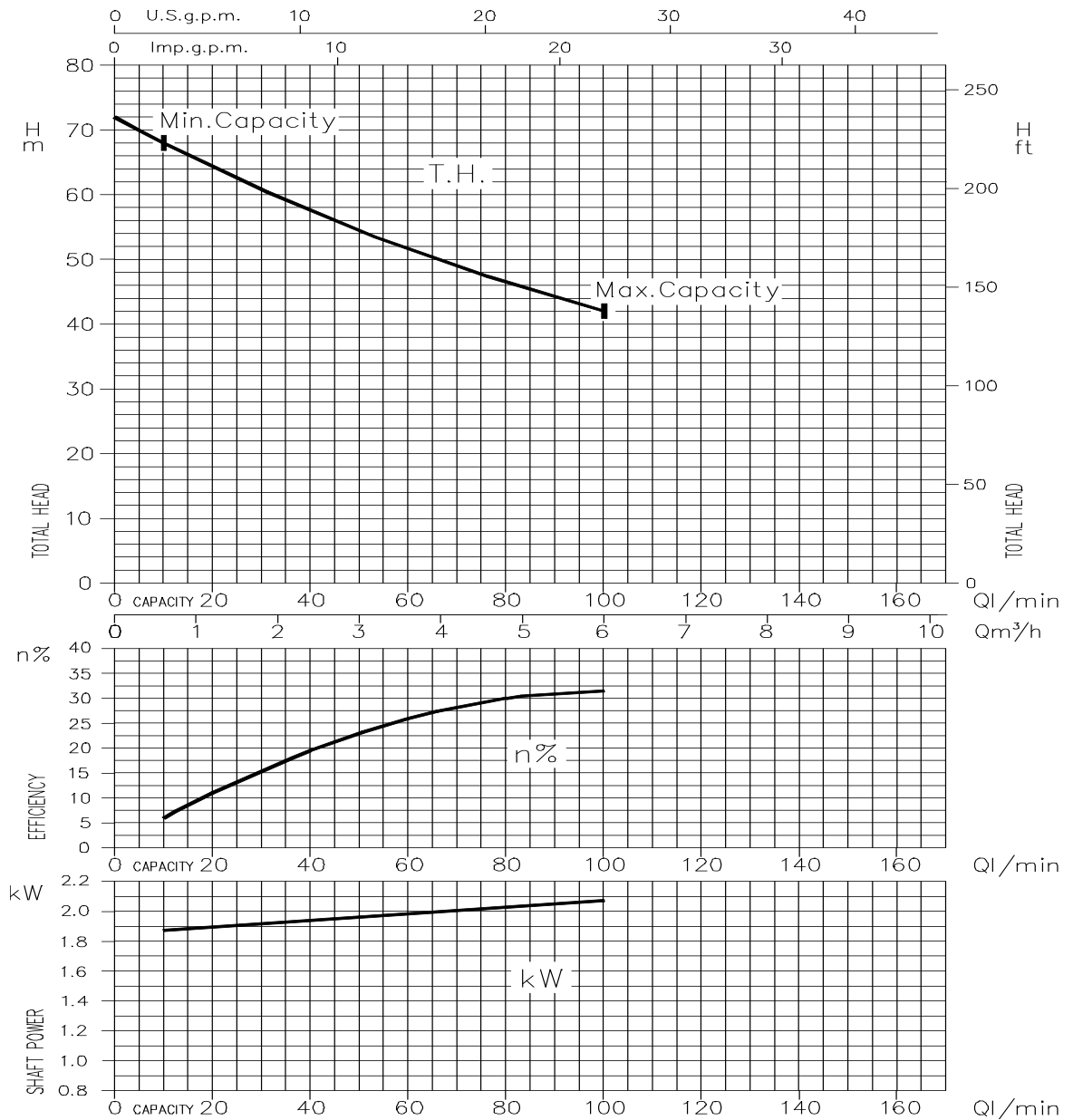

Rotation speed  $\approx 2850 \text{ min}^{-1}$   
 Test standard: ISO 9906:2012 – Grade 3B

AGC 1.50 - Impeller diameter = 143 mm

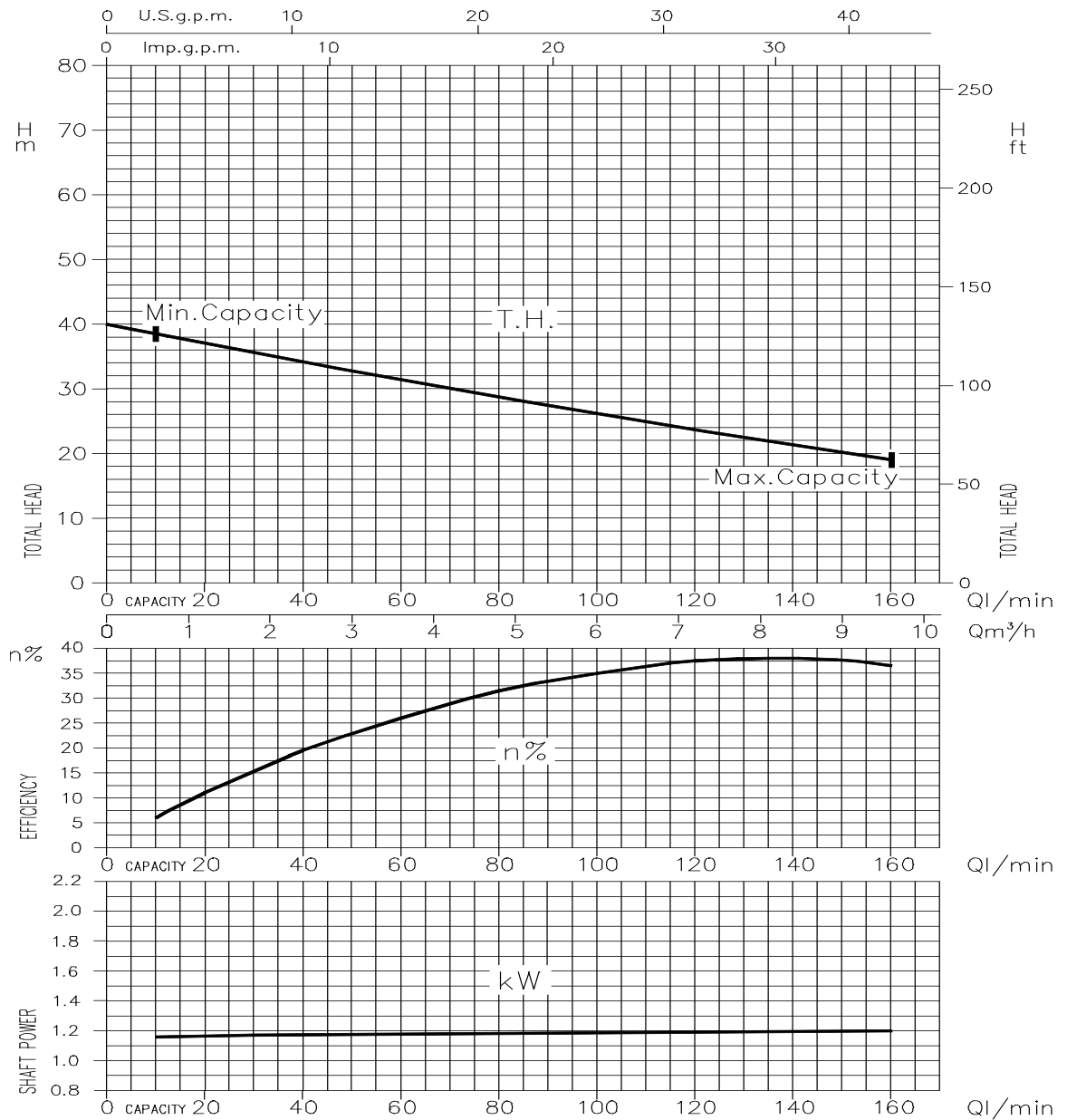

Rotation speed  $\approx 2850 \text{ min}^{-1}$   
 Test standard: ISO 9906:2012 – Grade 3B

AGC 2.00 - Impeller diameter = 157 mm

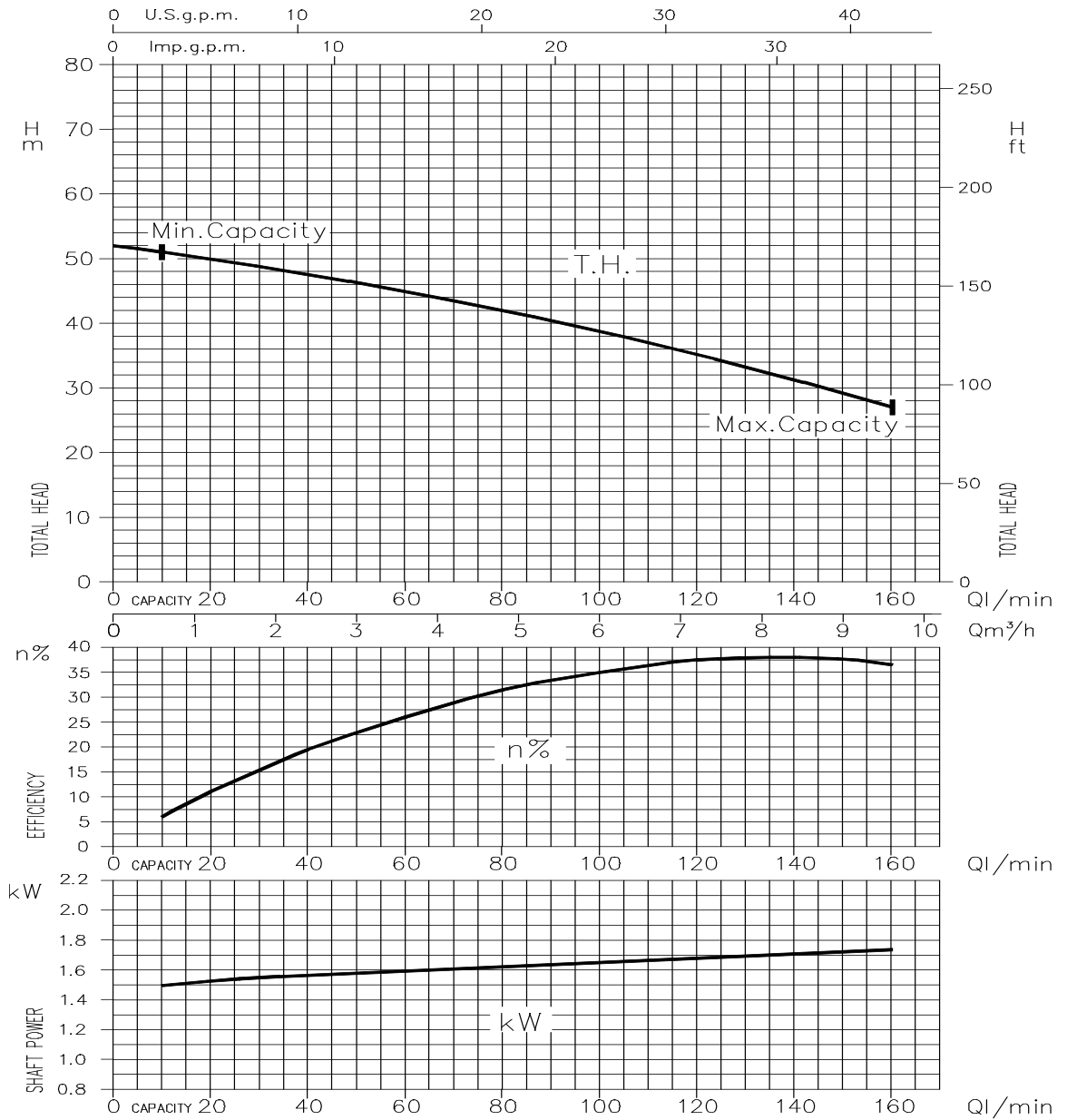

Rotation speed  $\approx 2850 \text{ min}^{-1}$   
 Test standard: ISO 9906:2012 – Grade 3B

AGC 3.00 - Impeller diameter = 164 mm

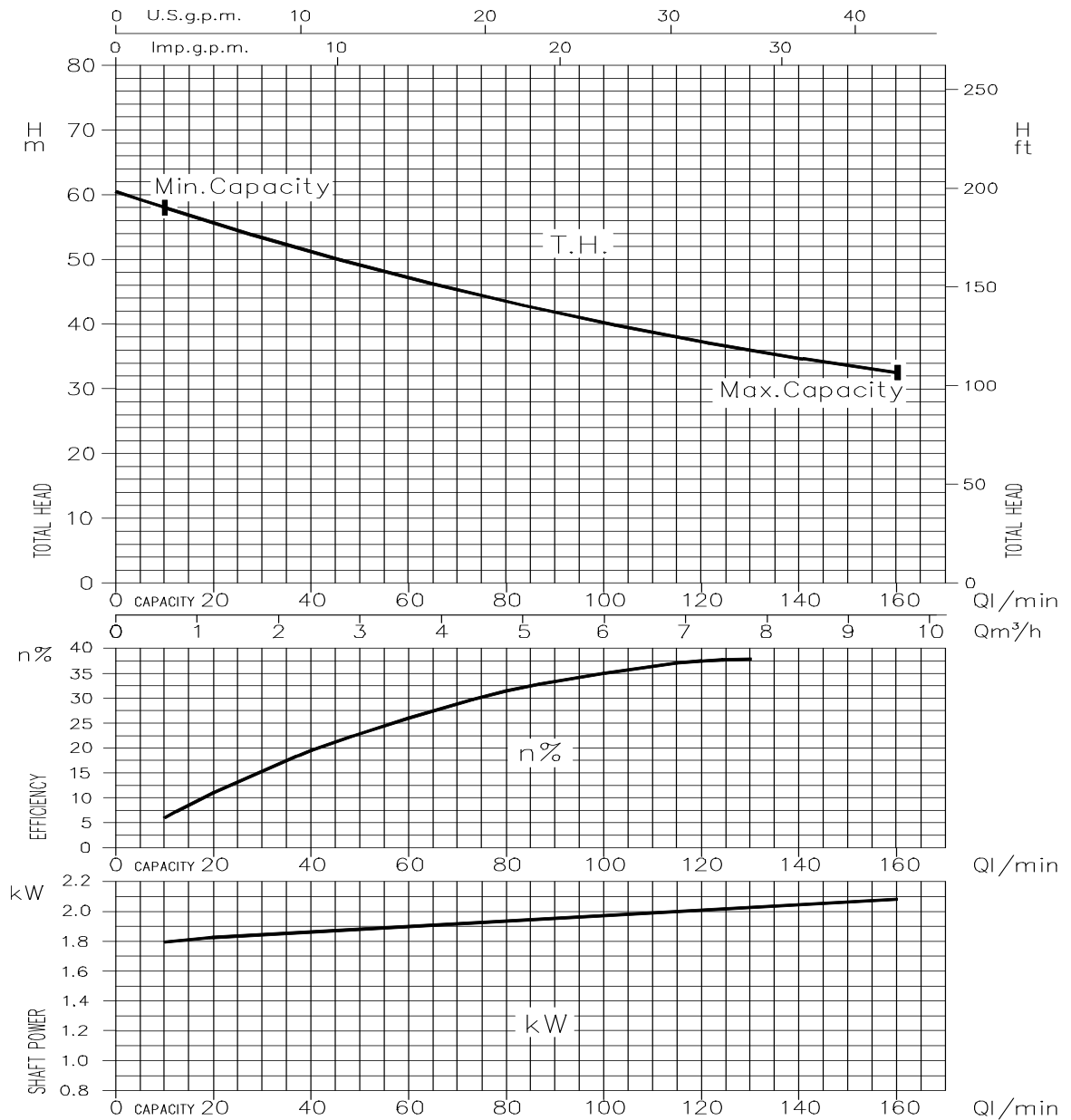

Rotation speed  $\approx 2850 \text{ min}^{-1}$   
 Test standard: ISO 9906:2012 – Grade 3B

SECTIONAL VIEW

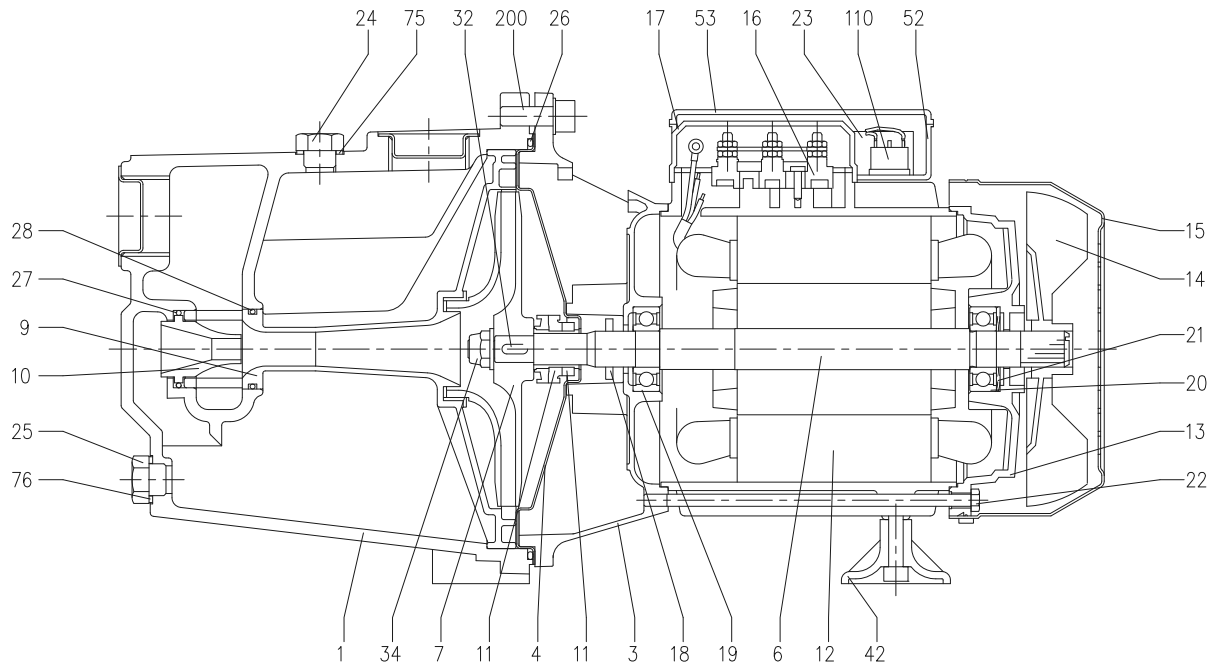

N°	PART NAME	MATERIAL	Q.TY
1	Casing	Cast iron	1
3	Motor bracket [1]	-	1
4	Casing cover [2]	AISI 304	1
6	Shaft with rotor	AISI 303 (wet extension)	1
7	Impeller [3]		1
9	Diffuser + Venturi tube	PPE+PS glass fibre reinforced	1
10	Venturi nozzle	PPE+PS glass fibre reinforced	1
11	Mechanical seal [4]	Carbon/Ceramic/NBR	1
12	Motor frame with stator	-	1
13	Motor cover	Aluminium	1
14	Fan	PA	1
15	Fan cover	Fe P04 Zincate	1
16	Terminal board	-	1
17	Terminal box cover [5]	Aluminium	1
18	Splash ring	NBR	1
19	Pump side ball bearing	-	1
20	Fan side ball bearing	-	1

N°	PART NAME	MATERIAL
21	Adjusting ring	Steel C70
22	Tie rod	Fe 42 Zincate
23	Capacitor [6]	-
24	Priming plug	Brass
25	Drain plug	Brass
26	O-ring	NBR
27	O-ring	NBR
28	O-ring [4]	NBR
32	Key	AISI 316
34	Impeller nut [7]	AISI 304
42	Foot	PP
52	Capacitor box [8]	ABS class V-0
53	Capacitor box cover [9]	ABS class V-0
75	Washer	Aluminium
76	Washer	Aluminium
110	Protector [8]	-
200	Screw	Zn Steel Cl. 8.8 ISO 898-1

[1] Material: Cast iron for version AGA1.50 - AGA 2.00 - AGA 3.00 - AGC 1.50 - AGC 2.00 - AGC 3.00  
Aluminium for version AGA 0.60 - AGA 0.75 - AGA 1.00

[2] Only for version AGA 0.60 - AGA 0.75 - AGA 1.00

[3] Material: PPE+PS glass fibre reinforced for version AGA 0.60 - AGA 0.75 - AGA 1.00  
Brass for version AGA 1.50 - AGA 2.00 - AGA 3.00 - AGC 1.50 - AGC 2.00 - AGC 3.00

[4] See constructions mechanical seal page 301

[5] Only for three phase

[6] Only for single phase

[7] Only for version with impeller in Brass

[8] Only for version single phase AGA 1.50 - AGA 2.00 - AGC 1.50 - AGC 2.00

[9] With gasket in NBR only for version single phase AGA 0.60 - AGA 0.75 - AGA 1.00

**MECHANICAL SEAL**

**UP TO 0.75 kW**

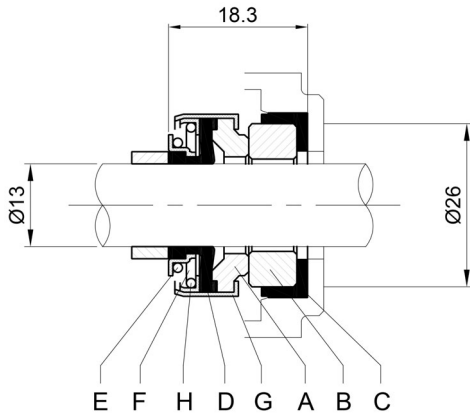

REF	PART NAME	MATERIAL
A	Rotary seal ring	Carbon graphite
B	Stationary seal ring	Ceramic
C	Gasket	NBR
D	Bellows	NBR
E	O-Ring	AISI 304
F	Self-driving spring	AISI 304
G	Frame	AISI 304
H	Retainer ring	AISI 304

**1.1 kW AND ABOVE**

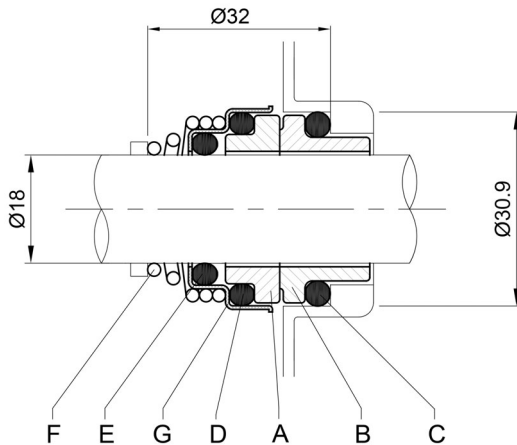

REF	PART NAME	MATERIAL
A	Rotary seal ring	Ceramic
B	Stationary seal ring	Carbon graphite
C	O-Ring	NBR
D	O-Ring	NBR
E	O-Ring	NBR
F	Self-driving spring	AISI 316
G	Frame	AISI 304

**BEARINGS**

Type pumps		Ball Bearing	
Single Phase	Three Phase	Pump side S.Phase / T.Phase	Fan side S.Phase / T.Phase
AGA 0.60 M	AGA 0.60 T	6202	6202
AGA 0.75 M	AGA 0.75 T	6202	6202
AGA 1.00 M	AGA 1.00 T	6202	6202
AGA 1.50 M	AGA 1.50 T	6204	6203
AGA 2.00 M	AGA 2.00 T	6204	6203
-	AGA 3.00 T	6204	6203
AGC 1.50 M	AGC 1.50 T	6204	6203
AGC 2.00 M	AGC 2.00 T	6204	6203
-	AGC 3.00 T	6204	6203



PUMP

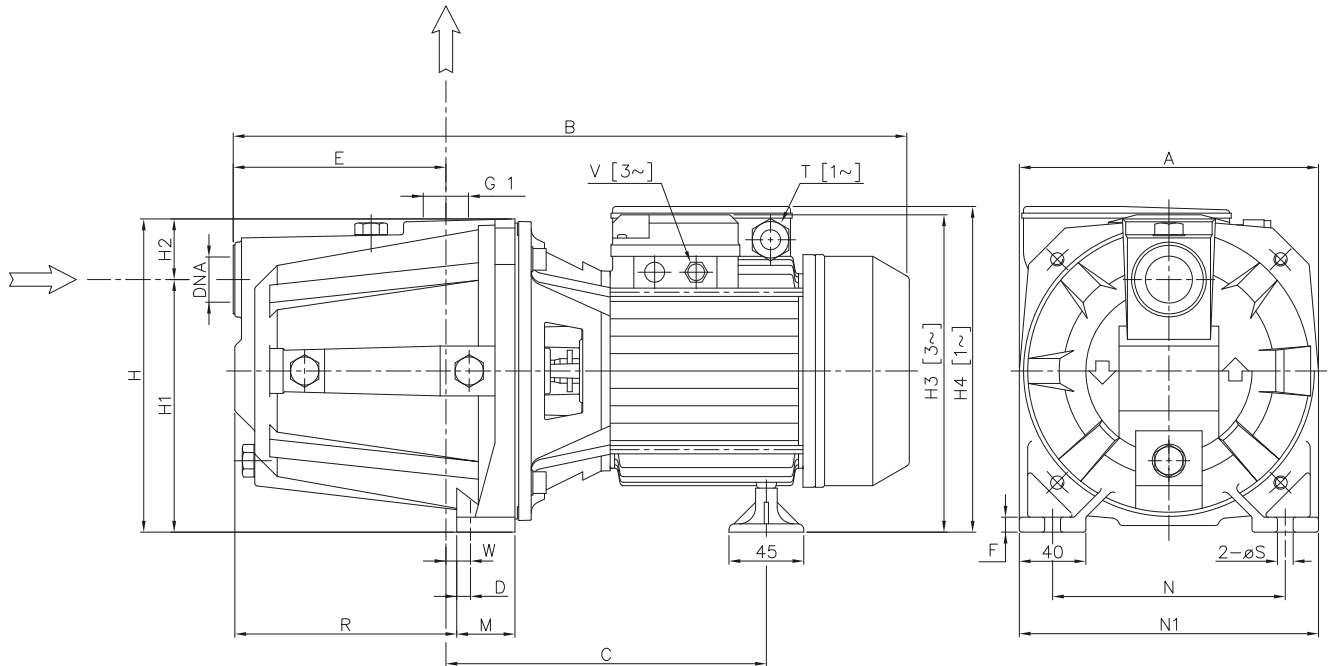

Pump type	Dimensions [mm]																			Weight [kgf]	
	A	B	C	D	E	F	H	H1	H2	[3~] H3	[1~] H4	M	N	N1	R	[1~] T	[3~] V	W	S		DNA
AGA 0.60 M	180	405	195	10.3	127	9	185	152	33	-	199	40	140	180	128.5	PG11	-	11.8	9.5	G 1	12.5
AGA 0.60 T	180	405	195	10.3	127	9	185	152	33	197.5	-	40	140	180	128.5	-	PG11	11.8	9.5	G 1	12.8
AGA 0.75 M	180	405	195	10.3	127	9	185	152	33	-	199	40	140	180	128.5	PG11	-	11.8	9.5	G 1	14
AGA 0.75 T	180	405	195	10.3	127	9	185	152	33	197.5	-	40	140	180	128.5	-	PG11	11.8	9.5	G 1	12.4
AGA 1.00 M	180	405	195	10.3	127	9	185	152	33	-	199	40	140	180	128.5	PG11	-	11.8	9.5	G 1	14.5
AGA 1.00 T	180	405	195	10.3	127	9	185	152	33	197.5	-	40	140	180	128.5	-	M16x1.5	11.8	9.5	G 1	14.8
AGA 1.50 M	220	520	244	10	157	10	223	170	53	-	247	48	175	220	167.5	PG13.5	-	15.5	9	G 1 1/2	29
AGA 1.50 T	220	520	244	10	157	10	223	170	53	229	-	48	175	220	167.5	-	M20x1.5	15.5	9	G 1 1/2	26.5
AGA 2.00 M	220	520	244	10	157	10	223	170	53	-	247	48	175	220	167.5	PG13.5	-	15.5	9	G 1 1/2	29
AGA 2.00 T	220	520	244	10	157	10	223	170	53	229	-	48	175	220	167.5	-	M20x1.5	15.5	9	G 1 1/2	28.6
AGA 3.00 T	220	521	244	10	157	10	223	170	53	229	-	48	175	220	167.5	-	M20x1.5	15.5	9	G 1 1/2	29.9
AGC 1.50 M	220	520	244	10	157	10	223	170	53	-	247	48	175	220	167.5	PG13.5	-	15.5	9	G 1 1/2	29
AGC 1.50 T	220	520	244	10	157	10	223	170	53	229	-	48	175	220	167.5	-	M20x1.5	15.5	9	G 1 1/2	28.3
AGC 2.00 M	220	520	244	10	157	10	223	170	53	-	247	48	175	220	167.5	PG13.5	-	15.5	9	G 1 1/2	29
AGC 2.00 T	220	521	244	10	157	10	223	170	53	229	-	48	175	220	167.5	-	M20x1.5	15.5	9	G 1 1/2	29.5
AGC 3.00 T	220	521	244	10	157	10	223	170	53	229	-	48	175	220	167.5	-	M20x1.5	15.5	9	G 1 1/2	29.9

[1 ~] Single phase  
 [3 ~] Three phase

## PACKING

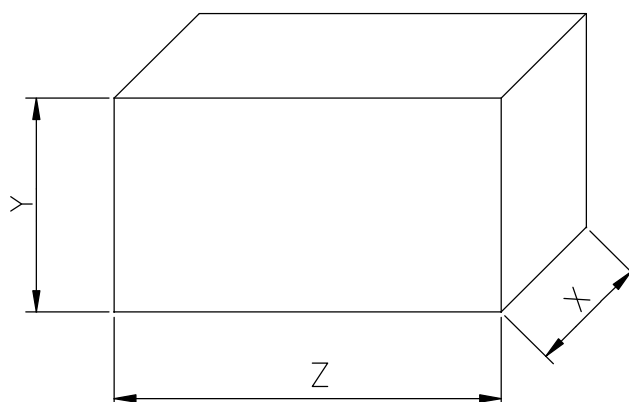

Type pumps		Packing [mm]					Weight [kgf]	
Single Phase	Three Phase	X		Y	Z		[1~]	[3~]
		[1~]	[3~]		[1~]	[3~]		
AGA 0.60 M	AGA 0.60 T	205	205	250	445	445	13	13.5
AGA 0.75 M	AGA 0.75 T	205	205	250	445	445	14.5	13.2
AGA 1.00 M	AGA 1.00 T	205	205	250	445	445	15.5	15.6
AGA 1.50 M	AGA 1.50 T	237	237	275	552	552	30	27.3
AGA 2.00 M	AGA 2.00 T	232	237	275	547	552	30.5	29.7
-	AGA 3.00 T	237	237	275	-	552	-	30.8
AGC 1.50 M	AGC 1.50 T	237	237	275	552	552	29.5	29.2
AGC 2.00 M	AGC 2.00 T	232	237	275	547	552	30	30.6
-	AGC 3.00 T	237	237	275	-	552	-	30.8

MOTOR DATA

Pump type	Power		Efficiency [IE2 / IE3]	Capacitor		Efficiency (% load) and power factor				Input [kW]	Full load current		Locked rotor current	
	[kW]	[HP]		[μF]	[V]	cos-φ	η %				[A]		[A]	
							50%	75%	100%		110 V	230 V	110 V	230 V
AGA 0.60 M	0,45	0,6	IE2	14	450	55,7	65,6	72,5	0,94	0,65	-	3,0	-	13,4
AGA 0.75 M	0,55	0,75	IE2	20	450	62,3	70,4	74,8	0,93	0,75	-	3,5	-	18,9
AGA 1.00 M	0,8	1,1	IE2	25	450	69,9	76,0	78,2	0,95	1,03	-	4,8	-	24,0
AGA 1.50 M	1,5	2,0	IE2	40	450	69,8	76,6	81,3	0,92	1,90	-	9,0	-	65,2
AGA 2.00 M	1,8	2,4	IE2	40	450	73,1	78,8	82,2	0,93	2,20	-	10,5	-	65,2
AGC 1.50 M	1,5	2,0	IE2	40	450	69,8	76,6	81,3	0,92	1,90	-	9,0	-	65,2
AGC 2.00 M	1,8	2,4	IE2	40	450	73,1	78,8	82,2	0,93	2,20	-	10,5	-	65,2

Pump type	Power		Efficiency	Efficiency (% load)			Input [kW]	Full load current		Locked rotor current	
	[kW]	[HP]		η %				[A]		[A]	
				50%	75%	100%		230 V	400 V	230 V	400 V
AGA 0.60 T	0.45	0.6	IE3	75.1	78.5	78.0	0.71	2.4	1.4	12.7	7.3
AGA 0.75 T	0.55	0.75	IE3	75.1	78.5	78.0	0.71	2.4	1.4	12.7	7.3
AGA 1.00 T	0.75	1	IE3	80.9	82.3	82.1	0.91	3.0	1.7	19.7	11.4
AGA 1.50 T	1.1	1.5	IE3	83.5	84.3	84.6	1.77	5.8	3.3	47.4	27.4
AGA 2.00 T	1.5	2	IE3	83.5	84.3	84.6	2.06	6.2	3.6	47.4	27.4
AGA 3.00 T	2.2	3	IE3	86.2	87.0	86.0	2.55	8.2	4.7	66.6	38.4
AGC 1.50 T	1.1	1.5	IE3	83.5	84.3	84.6	1.77	5.8	3.3	47.4	27.4
AGC 2.00 T	1.5	2	IE3	84.2	86.8	86.9	2.23	7.6	4.4	66.6	38.4
AGC 3.00 T	2.2	3	IE3	86.2	87.0	86.0	2.55	8.2	4.7	66.6	38.4

NOISE DATA

Pump type		L <sub>pA</sub> - dB(A) *
Single Phase	Three Phase	
AGA 0.60 M	AGA 0.60 T	71
AGA 0.75 M	AGA 0.75 T	
AGA 1.00 M	AGA 1.00 T	
AGA 1.50 M	AGA 1.50 T	76
AGA 2.00 M	AGA 2.00 T	
-	AGA 3.00 T	
AGC 1.50 M	AGC 1.50 T	
AGC 2.00 M	AGC 2.00 T	
-	AGC 3.00 T	

\* Mean value of several measures at 1m distance around  
Tolerance ± 2.5 dB.



**EBARA Pumps Europe S.p.A.**  
Via Torri di Confine 2/1 int. C  
36053 Gambellara (Vicenza), Italy  
Phone +39 0444 706811  
ebarapumps.epe@ebaracom  
www.ebaraeurope.com

**EBARA Pumps Europe S.p.A. GERMANY**  
Elisabeth-Selbert-Straße 2  
63110 Rodgau, Germany  
Phone +49 (0) 6106-660 99-0  
info.epde@ebaracom

**EBARA Pumps South Africa (PTY) LTD**  
26 Kyalami Boulevard,  
Kyalami Business Park, 1684, Midrand,  
Gauteng, South Africa  
Phone +27 11 466 1844  
ebaraeurope@ebaracom

**EBARA Pumps Europe S.p.A. UK**  
Unit A, Park 34  
Collett Way - Didcot  
Oxfordshire - OX11 7WB, United Kingdom  
Phone +44 1895 439027  
marketing.epuk@ebaracom

**EBARA Pumps Europe S.p.A. FRANCE**  
122, Rue Pasteur  
69780 Toussieu, France  
Phone: +33 04 72 76 94 82  
mktg.epr@ebaracom

**EBARA Pumps East Africa**  
Delta Corner Tower 2, 13th Floor, Office 1308,  
Chiromo Road, Westlands  
P.O. Box 13796-00800, Nairobi  
Phone: +254(0)722913119  
info.epea@ebaracom

**EBARA POMPY POLSKA Sp. z o.o.**  
ul. Działkowa 115 A  
02-234 Warszawa, Poland  
Phone +48 22 3909920  
marketing.epl@ebaracom

**EBARA Pumps RUS Ltd.**  
Prospekt Andropov 18, building 7, floor 11  
115432 Moscow  
Phone +7 499 6830133  
mktg.epr@ebaracom