

MXH 2,4,8,16

Horizontal Multi-Stage Close Coupled Pumps in stainless steel



Construction

Horizontal multi-stage close coupled pumps in **chrome-nickel stainless steel**.

Compact and robust construction, without protruding flange and with single-piece lantern bracket and base.

Single-piece barrel casing, with front suction port above pumps axis and radial delivery at top.

Filling and draining plugs on the middle of the pump, accessible from any side (like the terminal box).

Version with frequency converter (on request)

Applications

For water supply.

For clean liquids, without abrasives, which are non-aggressive for stainless steel (with suitable seal materials, on request).

Universal pump, for domestic use, for civil and industrial applications, for garden use and irrigation.

Operating conditions

Liquid temperature from - 15 °C to + 110 °C.

Ambient temperature up to 40 °C.

Maximum permissible pressure in the pump casing: 8 bar.

Continuous duty (S3 60% for 1,5-1,8 kW).

Motor

2-pole induction motor, 50 Hz ($n \approx 2800$ rpm).

MXH: three-phase 230/400 V $\pm 10\%$ up to 3 kW;
400/690 V $\pm 10\%$ from 3,7 to 4 kW.

MXHM: single-phase 230 V $\pm 10\%$, with thermal protector.
Capacitor inside the terminal box.

Insulation class F. Protection IP 54.

Motor suitable for operation with frequency converter from 1,1 kW.

IE2 efficiency class for single-phase motors up to 1,1 kW.

IE3 efficiency class for three-phase motors (IE2 up to 0,65 kW).

Constructed in accordance with: EN 60034-1; EN 60034-30-1.
EN 60335-1, EN 60335-2-41.

Special features on request

- Other voltages. - Frequency 60 Hz (as per 60 Hz data sheet).
- Protection IP 55. - Special mechanical seal
- Pump casing seal rings in FPM.
- Higher or lower liquid or ambient temperatures.
- Motor suitable for operation with frequency converter up to 0,75 kW.

Materials

Component	Material
Pump casing	Chrome-nickel steel 1.4301 EN 10088 (AISI 304)
Stage casing	Chrome-nickel steel 1.4301 EN 10088 (AISI 304)
Wear ring	PPS
Impeller	Chrome-nickel steel 1.4301 EN 10088 (AISI 304)
Casing cover	Chrome-nickel steel 1.4301 EN 10088 (AISI 304)
Spacer sleeve	Chrome-nickel steel 1.4301 EN 10088 (AISI 304)
Pump shaft	Chrome-nickel steel 1.4305 EN 10088 (AISI 303)
Plug	Chrome-nickel steel 1.4305 EN 10088 (AISI 303)
Mechanical seal with seat according to ISO 3069	Ceramic alumina, carbon, EPDM (Other materials on request)

Coverage chart $n \approx 2800$ rpm

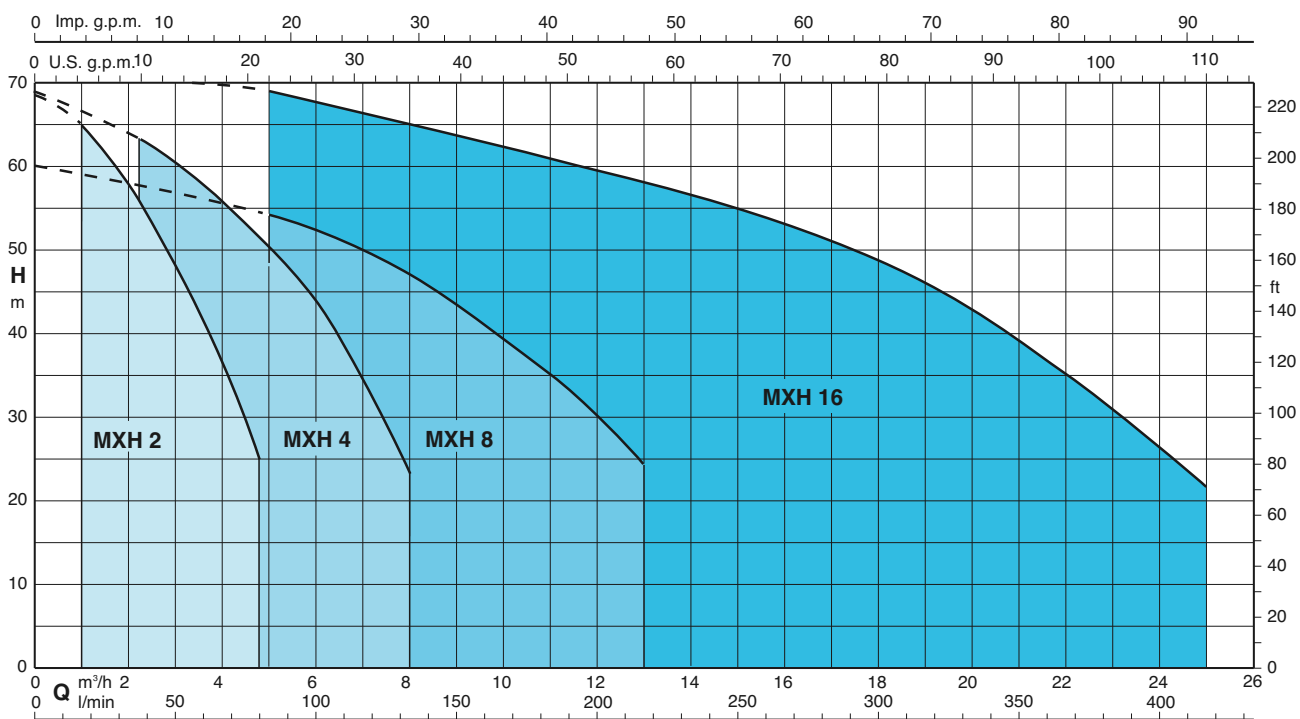

Pumps with frequency converter

The **MXH EI** pumps are available with power from 0,55 kW up to 4 kW, the pumps are equipped with **I-MAT** installed on board which allows to realize a variable-speed system extremely compact and efficient, ideal in applications of water supply and in the distribution of hot and cold water.

The pump is equipped with transducers suitable for operation and is already programmed at the factory.

Advantages

- Energy saving
- Compact design
- Easy to use
- Programmable to suit the system requirements
- Reliability

Costruction

The system comprises of:

- Pump
- Induction motor
- I-MAT Frequency converter
- Motor adapter for the motor mounting of the frequency converter
- Connection cable between frequency converter and induction motor
- Transducers

Main features

Rated motor power output from 0,55 kW to 4 kW

Control range from 1750 to 2900 rpm (2-pole)

Protection against dry running

Protection against operations with closed valve ports

Protection against system leakages

Protection against overcurrent in the motor

Protection against overvoltage and undervoltage of the power supply

Protection against current unbalances between phases



Operating modes



Constant pressure mode with pressure transducer

In this mode, the system maintains the preset pressure when the flow required by the installation changes.

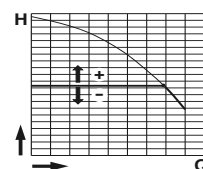

Proportional pressure mode with pressure transducer

In this mode the system changes the working pressure according to the required flow rate.

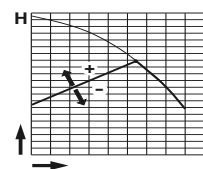

Constant flow mode with flow meter

In this mode the system maintains a constant flow rate value in a point of the installation according to the required pressure.

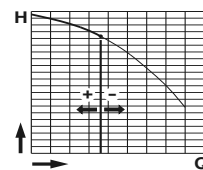

Fixed speed mode with setting of the speed preferential rotation.

In this mode, by changing the working frequency, you may choose any operational curve included within the working range.

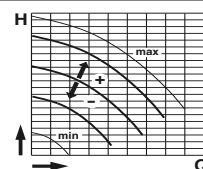

Constant temperature mode with temperature transducer

In this mode the system keeps the temperature constant inside a system by changing the speed of the pump.

Performance n ≈ 2800 rpm

3 ~	230 V		400 V	1 ~	230 V		P ₁	P ₂		Q	m ³ /h									
	A	A			A	kW		kW	HP		0	1	1,5	2	2,5	3	3,5	4	4,25	4,8
MXH 202E	1,7	1		MXHM 202E	2,3	0,5	0,25	0,34	H m	0	16,6	25	33,3	41,6	50	58,3	66,6	70,8	80	
MXH 203E	2,4	1,4		MXHM 203E	3	0,65	0,37	0,5		22	20	18,5	17	15,3	13,4	11,4	9,3	8,2	5,6	
MXH 204/A	2,8	1,6		MXHM 204/A	4,2	0,9	0,55	0,75		33	31	29	27	24,5	21,7	18,6	15,5	13,8	9	
MXH 205/B	3,5	2		MXHM 205/A	5,4	1,2	0,75	1		45	42,5	40,4	37,5	34,5	30,8	26,7	22,4	20,1	14,8	
MXH 206/C	4,7	2,7		MXHM 206	7,4	1,5	1,1	1,5		57	53,5	50,5	47,5	43,5	39	34	28,5	25,8	19	
										68,5	65	61,5	58	53,5	48	43	36,5	33,5	25	

3 ~	230 V		400 V	1 ~	230 V		P ₁	P ₂		Q	m ³ /h								
	A	A			A	kW		kW	HP		0	2,25	3	3,5	4	4,5	5	6	7
MXH 402E	2,4	1,4		MXHM 402E	3	0,65	0,37	0,5	H m	0	37,5	50	58,3	66,6	75	83,3	100	116	133
MXH 403/A	2,8	1,6		MXHM 403/A	4,2	0,9	0,55	0,75		22,5	20	19	18,5	17,5	16	15	12,5	9,5	6
MXH 404/B	3,5	2		MXHM 404/A	5,4	1,2	0,75	1		33	30	29	27,5	26	24,5	23	19,5	15	9,5
MXH 405/C	4,7	2,7		MXHM 405	7,4	1,5	1,1	1,5		44,5	40,5	38	36,5	35	33	31	26	20	12,5
MXH 406/A	6,2	3,6		MXHM 406	9,2	2	1,5	2		56,5	52	50	47,5	45,5	43	40	33,5	26	16,5
										68,5	63	60	58	56	53,5	51	44	35	23

3 ~	230 V		400 V	1 ~	230 V		P ₁	P ₂		Q	m ³ /h									
	A	A			A	kW		kW	HP		0	5	6	7	8	9	10	11	12	13
MXH 802/B	3,5	2		MXHM 802/A	5,4	1,2	0,75	1	H m	0	83,3	100	116	133	150	166	183	200	216	
MXH 803/A	4,7	2,7		MXHM 803	7,4	1,5	1,1	1,5		22,5	20,5	20	19	18	16,5	15	13	11	8,5	
MXH 804/A	6,2	3,6		MXHM 804	9,2	2	1,5	2		36	32	30,5	29	27,5	25,5	23	20	17	14	
MXH 805/B	8,3	4,8		MXHM 805/A	11,2	2,5	1,8	2,5		48	42,5	41	39	37	34,5	32	28	24	19,5	
										60	54	52	49,5	47	43,5	39,5	35	29,5	24	

3 ~	230 V		400 V	P ₂	Q	m ³ /h									
	A	A				kW	HP	0	5	8	11	14	16	18	20
MXH 1602/A	6,2	3,6		1,5	2	0	83,3	133	183	233	266	300	333	366	416
MXH 1603/B	8,3	4,8		1,8	2,5	24	23	21,7	20,5	18,8	17,5	15,8	14	11,5	6,5
MXH 1604/A	11,5	6,6		3	4	36	34	31,8	29,5	26,8	24,8	22,4	19,2	15,3	8,8
MXH 1605/B		9,6		3,7	5	48	46,5	44,5	41,5	38	36	33	29	23	14
MXH 1606/B		9,6		4	5,5	60	57,5	55	51,5	48	45	42	37,5	31,5	19
						71	68	65	61	56	53	49	44	36	22

P₁ Max. power input.
P₂ Rated motor power output.

Test results with clean cold water, without gas content.
Tolerances according to UNI EN ISO 9906:2012

+ 0,5 m security margin on NPSH-value is necessary.

Characteristic curves $n \approx 2800$ rpm

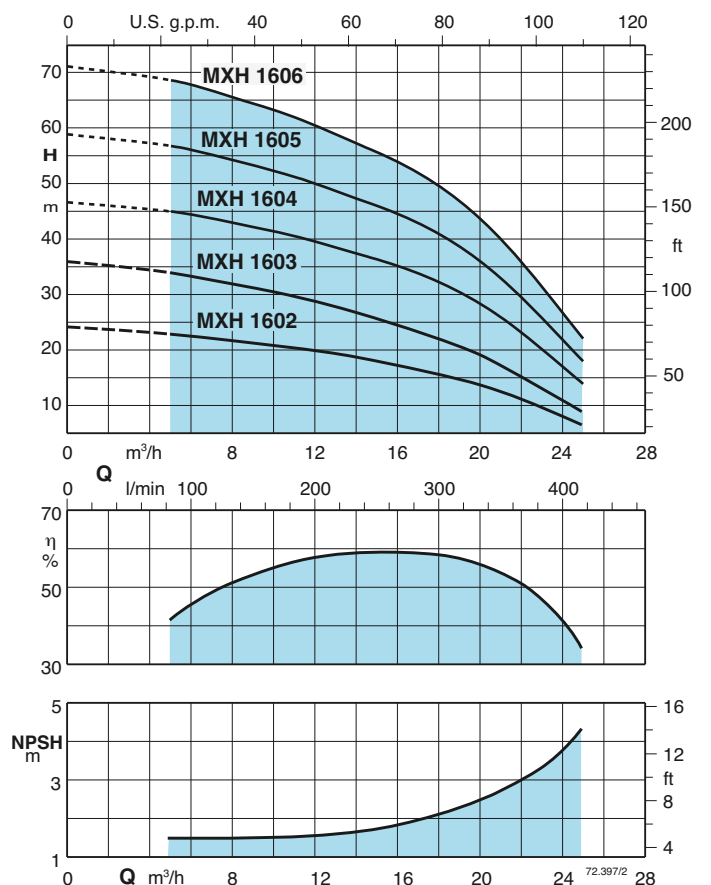
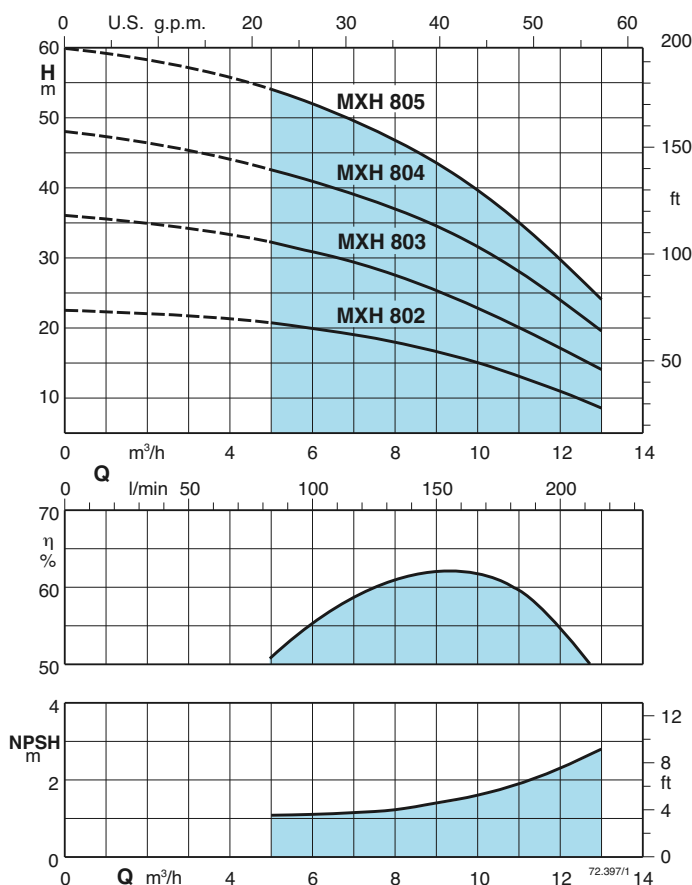
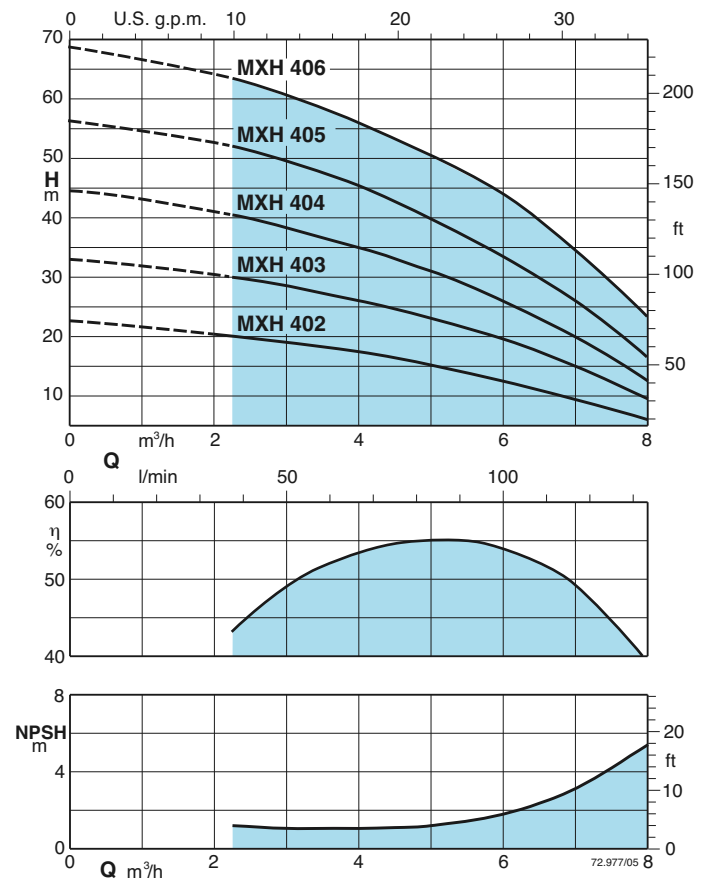
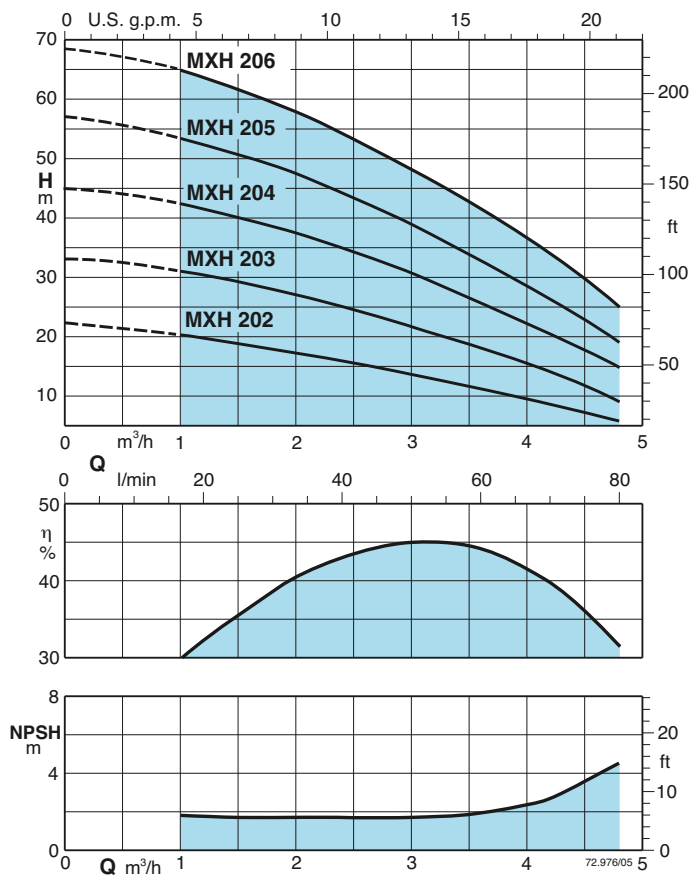

Dimensions and weights

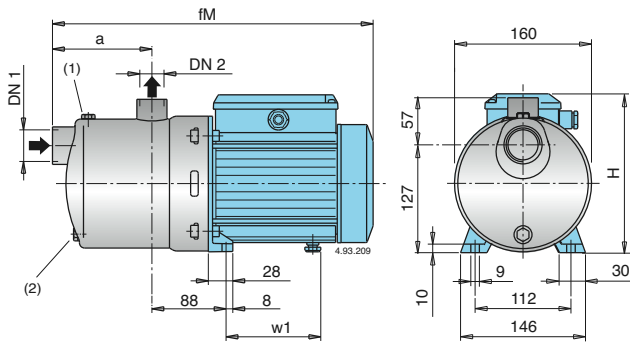

TYPE	DN1 ISO 228	DN2 ISO 228	mm				kg	
			fM	a	H	w1	MXH	MXHM
MXH 202E - MXHM 202E	G 1 1/4	G 1	331	94	176	98,5	6.5	6.5
MXH 203E - MXHM 203E	G 1 1/4	G 1	331	94	176	98,5	7.5	7.4
MXH 204/A - MXHM 204/A	G 1 1/4	G 1	381	118	193	112	10.3	11.2
MXH 205/B - MXHM 205/A	G 1 1/4	G 1	405	142	193	112	12.8	12.8
MXH 402E - MXHM 402E	G 1 1/4	G 1	331	94	176	98,5	7.1	7.2
MXH 403/A - MXHM 403/A	G 1 1/4	G 1	357	94	193	112	9.6	10.7
MXH 404/B - MXHM 404/A	G 1 1/4	G 1	381	118	193	112	12.2	12.2
MXH 802/B - MXHM 802/A	G 1 1/2	G 1	381	118	193	112	11.7	11.9

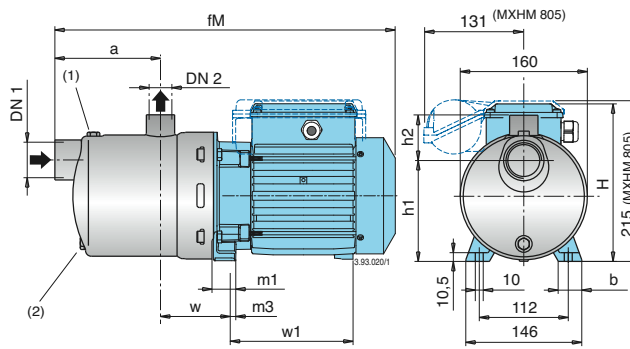

TYPE	DN1 ISO 228	DN2 ISO 228	mm											kg	
			fM	a	w	H	h1	h2	m1	m3	b	w1	MXH	MXHM	
MXH 206/C - MXHM 206	G 1 1/4	G 1	500	166	88	210	127	57	31	10	30,5	167	16.9	16.8	
MXH 405/C - MXHM 405	G 1 1/4	G 1	476	142	88	210	127	57	31	10	30,5	167	16.1	16.2	
MXH 406/A - MXHM 406	G 1 1/4	G 1	500	166	88	210	127	57	31	10	30,5	167	18.4	18.1	
MXH 803/A - MXHM 803	G 1 1/2	G 1	452	118	88	210	127	57	31	10	30,5	167	15.2	15.2	
MXH 804/A - MXHM 804	G 1 1/2	G 1	482	148	88	210	127	57	31	10	30,5	167	17.3	17.6	
MXH 805/B - MXHM 805/A	G 1 1/2	G 1	552	178	88	210	127	57	31	10	30,5	207	21.2	21.6	
MXH 1602/A	G 2	G 1 1/2	476	128	101	210	117	70	31	10	30,5	167	16.8	-	
MXH 1603/B	G 2	G 1 1/2	516	128	101	210	117	70	31	10	30,5	207	20.1	-	
MXH 1604/A	G 2	G 1 1/2	612	166	113	235	132	70	44	12	38	232	31.7	-	
MXH 1605/B	G 2	G 1 1/2	650	203	113	235	132	70	44	12	38	232	35.7	-	
MXH 1606/B	G 2	G 1 1/2	687	241	113	235	132	70	44	12	38	232	36.8	-	

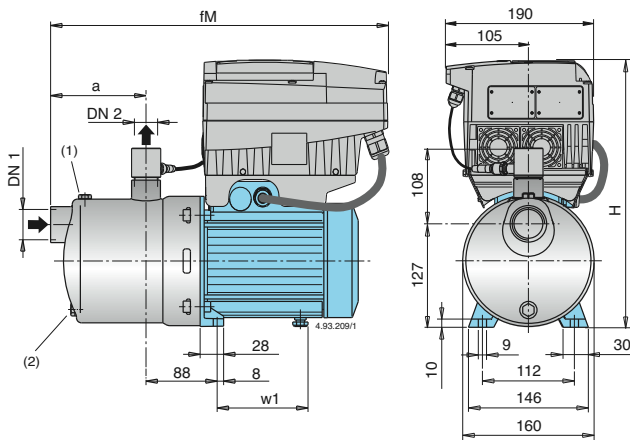

TYPE	DN1 ISO 228	DN2 ISO 228	mm				kg
			fM	a	H	w1	
MXH EI 204/A	G 1 1/4	G 1	444	118	349	112	17,2
MXH EI 205/B	G 1 1/4	G 1	468	142	349	112	17,9
MXH EI 403/A	G 1 1/4	G 1	420	94	349	112	15,7
MXH EI 404/B	G 1 1/4	G 1	444	118	349	112	19,7

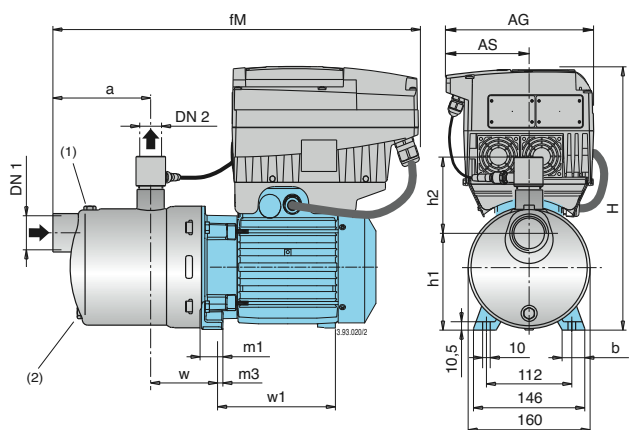

TYPE	DN1 ISO 228	DN2 ISO 228	mm											kg	
			fM	AG	AS	a	w	H	h1	h2	m1	m3	b		w1
MXH EI 206/C	G 1 1/4	G 1	532	190	105	166	88	368	127	108	31	10	30,5	167	24,3
MXH EI 405/C	G 1 1/4	G 1	508	190	105	142	88	368	127	108	31	10	30,5	167	23,2
MXH EI 406/A	G 1 1/4	G 1	532	190	105	166	88	368	127	108	31	10	30,5	167	25,9
MXH EI 803/A	G 1 1/2	G 1	484	190	105	118	88	368	127	108	31	10	30,5	167	23
MXH EI 804/A	G 1 1/2	G 1	514	190	105	148	88	368	127	108	31	10	30,5	167	24,1
MXH EI 805/B	G 1 1/2	G 1	552	190	105	178	88	368	127	108	31	10	30,5	207	28,4
MXH EI 1603/B	G 2	G 1 1/2	516	190	105	128	101	368	117	122	31	10	30,5	207	27,2
MXH EI 1604/A	G 2	G 1 1/2	627	210	118	166	113	391	132	122	44	12	38	232	41,3
MXH EI 1605/B	G 2	G 1 1/2	665	210	118	203	113	391	132	122	44	12	38	232	42,8
MXH EI 1606/B	G 2	G 1 1/2	702	210	118	241	113	391	132	122	44	12	38	232	43,9

(1) Filling (2) Draining

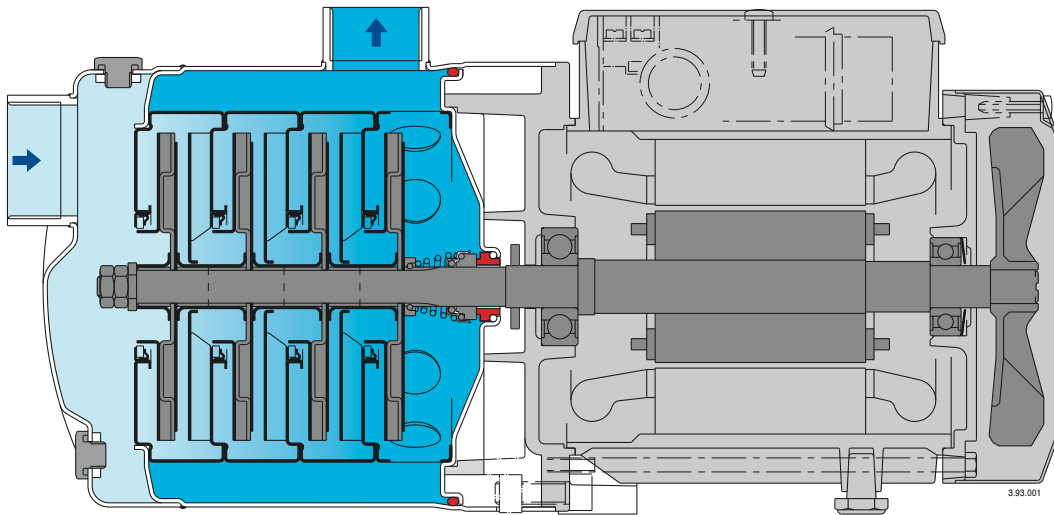
Features**Extra safety**

against running dry, with the suction port above pump axis.

Reliable

All hydraulic parts in contact with the pumped liquid are of stainless steel.
For liquids from -15 °C to 110 °C.

Robust

Single-piece, thick barrel casing.

Compact

Single-piece lantern bracket and base.
Without protruding flange.

Greater protection

against leakage, with the pump casing cover separated from the motor shield.
Possibility of inspecting the seal through the side apertures between the two walls.
Greater protection against water entering the motor from outside provided by an extension of the pump casing around the lantern bracket.



Construction

Horizontal multi-stage close coupled pumps in **chrome-nickel-molybdenum stainless steel AISI 316L**.

Compact and robust construction, without protruding flange and with single-piece lantern bracket and base.

Single-piece barrel casing, with front suction port above pumps axis and radial delivery at top.

Filling and draining plugs on the middle of the pump, accessible from any side (like the terminal box).

Applications

For water supply.

For clean liquids, without abrasives, which are non-aggressive for stainless steel (with suitable seal materials, on request).

Universal pump, for domestic use, for civil and industrial applications, for garden use and irrigation.

Operating conditions

Liquid temperature from - 15 °C to + 110 °C.

Ambient temperature up to 40 °C.

Maximum permissible pressure in the pump casing: 8 bar.

Continuous duty (S3 60% for 1,5-1,8 kW).

Motor

2-pole induction motor, 50 Hz ($n \approx 2800$ rpm).

MXHL: three-phase 230/400 V $\pm 10\%$.

MXHLM: single-phase 230 V $\pm 10\%$, with thermal protector.

Capacitor inside the terminal box.

Insulation class F. Protection IP 54.

Motor suitable for operation with frequency converter from 1,1 kW.

IE2 efficiency class for single-phase motors up to 1,1 kW.

IE3 efficiency class for three-phase motors (IE2 up to 0,65 kW).

Constructed in accordance with: EN 60034-1; EN 60034-30-1.

EN 60335-1, EN 60335-2-41.

Materials

Component	Material
Pump casing	Cr-Ni-Mo steel 1.4404 EN 10088 (AISI 316L)
Stage casing	Cr-Ni-Mo steel 1.4404 EN 10088 (AISI 316L)
Wear ring	PPS
Impeller	Cr-Ni-Mo steel 1.4404 EN 10088 (AISI 316L)
Casing cover	Cr-Ni-Mo steel 1.4404 EN 10088 (AISI 316L)
Spacer sleeve	Cr-Ni-Mo steel 1.4404 EN 10088 (AISI 316L)
Pump shaft	Cr-Ni-Mo steel 1.4404 EN 10088 (AISI 316L)
Plug	Cr-Ni-Mo steel 1.4404 EN 10088 (AISI 316L)
Mechanical seal with seat according to ISO 3069	Ceramic alumina, carbon, EPDM (Other materials on request)

Special features on request

- Other voltages.
- Frequency 60 Hz (as per 60 Hz data sheet).
- Protection IP 55.
- Special mechanical seal
- Pump casing seal rings in FPM.
- Higher or lower liquid or ambient temperatures.
- Motor suitable for operation with frequency converter up to 0,75 kW.

Coverage chart $n \approx 2800$ rpm

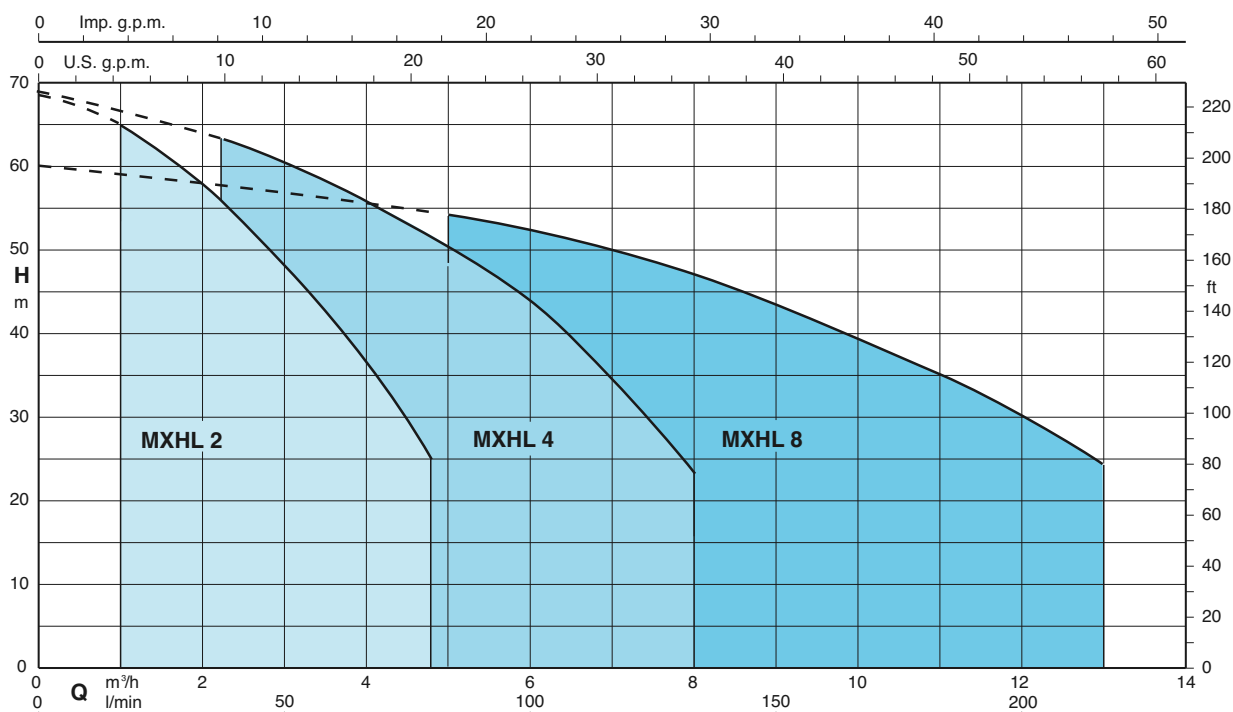

Performance $n \approx 2800$ rpm

	3 ~ 230 V 400 V		1 ~ 230 V		P ₁		P ₂		Q										
	A	A	A	kW	kW	HP	m ³ /h	l/min		0	1	1,5	2	2,5	3	3,5	4	4,25	4,8
MXHL 202E	1,7	1	MXHLM 202E	2,3	0,5	0,25	0,34	H m	22	20	18,5	17	15,3	13,4	11,4	9,3	8,2	5,6	
MXHL 203E	2,4	1,4	MXHLM 203E	3	0,65	0,37	0,5		33	31	29	27	24,5	21,7	18,6	15,5	13,8	9	
MXHL 204/A	2,8	1,6	MXHLM 204/A	4,2	0,9	0,55	0,75		45	42,5	40,4	37,5	34,5	30,8	26,7	22,4	20,1	14,8	
MXHL 205/B	3,5	2	MXHLM 205/A	5,4	1,2	0,75	1		57	53,5	50,5	47,5	43,5	39	34	28,5	25,8	19	
MXHL 206/C	4,7	2,7	MXHLM 206	7,4	1,5	1,1	1,5		68,5	65	61,5	58	53,5	48	43	36,5	33,5	25	

	3 ~ 230 V 400 V		1 ~ 230 V		P ₁		P ₂		Q										
	A	A	A	kW	kW	HP	m ³ /h	l/min		0	2,25	3	3,5	4	4,5	5	6	7	8
MXHL 402E	2,4	1,4	MXHLM 402E	3	0,65	0,37	0,5	H m	22,5	20	19	18,5	17,5	16	15	12,5	9,5	6	
MXHL 403/A	2,8	1,6	MXHLM 403/A	4,2	0,9	0,55	0,75		33	30	29	27,5	26	24,5	23	19,5	15	9,5	
MXHL 404/B	3,5	2	MXHLM 404/A	5,4	1,2	0,75	1		44,5	40,5	38	36,5	35	33	31	26	20	12,5	
MXHL 405/C	4,7	2,7	MXHLM 405	7,4	1,5	1,1	1,5		56,5	52	50	47,5	45,5	43	40	33,5	26	16,5	
MXHL 406/A	6,2	3,6	MXHLM 406	9,2	2	1,5	2		68,5	63	60	58	56	53,5	51	44	35	23	

	3 ~ 230 V 400 V		1 ~ 230 V		P ₁		P ₂		Q										
	A	A	A	kW	kW	HP	m ³ /h	l/min		0	5	6	7	8	9	10	11	12	13
MXHL 802/B	3,5	2	MXHLM 802/A	5,4	1,2	0,75	1	H m	22,5	20,5	20	19	18	16,5	15	13	11	8,5	
MXHL 803/A	4,7	2,7	MXHLM 803	7,4	1,5	1,1	1,5		36	32	30,5	29	27,5	25,5	23	20	17	14	
MXHL 804/A	6,2	3,6	MXHLM 804	9,2	2	1,5	2		48	42,5	41	39	37	34,5	32	28	24	19,5	
MXHL 805/B	8,3	4,8	MXHLM 805	11,2	2,5	1,8	2,5		60	54	52	49,5	47	43,5	39,5	35	29,5	24	

P1 Max. power input.

P2 Rated motor power output.

Test results with clean cold water, without gas content.

Tolerances according to UNI EN ISO 9906:2012

+ 0,5 m security margin on NPSH-value is necessary.

Dimensions and weights

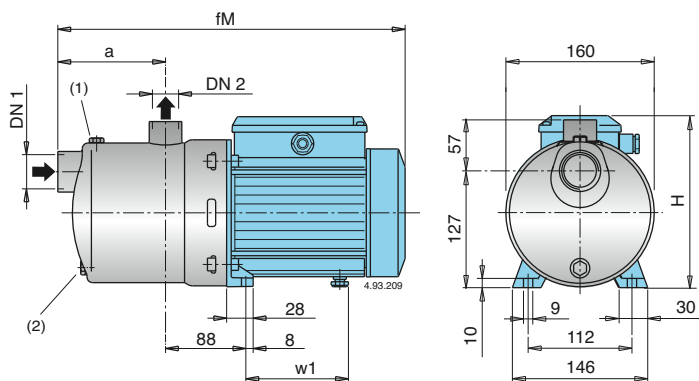

TYPE	DN1	DN2	mm				kg	
			fM	a	H	w1	MXHL	MXHLM
MXHL 202E - MXHLM 202E	G 1 1/4	G 1	331	94	176	98,5	6,6	6,6
MXHL 203E - MXHLM 203E	G 1 1/4	G 1	331	94	176	98,5	7,5	7,6
MXHL 204/A - MXHLM 204/A	G 1 1/4	G 1	381	118	193	112	10,3	11,2
MXHL 205/B - MXHLM 205/A	G 1 1/4	G 1	405	142	193	112	12,9	12,8
MXHL 402E - MXHLM 402E	G 1 1/4	G 1	331	94	176	98,5	7,1	7,2
MXHL 403/A - MXHLM 403/A	G 1 1/4	G 1	357	94	193	112	9,6	10,7
MXHL 404/B - MXHLM 404/A	G 1 1/4	G 1	381	118	193	112	12,3	12,2
MXHL 802/B - MXHLM 802/A	G 1 1/2	G 1	381	118	193	112	11,7	11,9

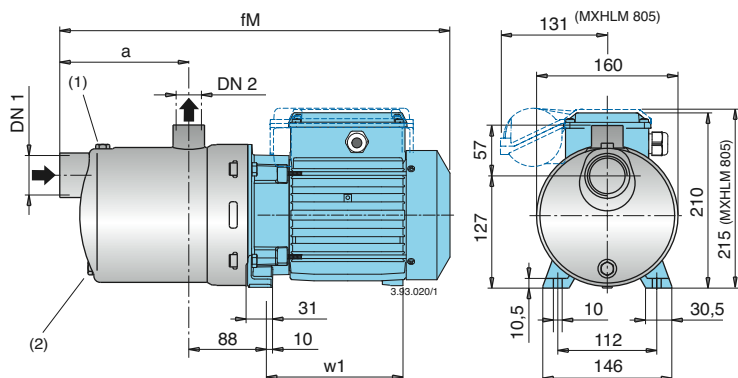

TYPE	DN1	DN2	mm			kg	
			fM	a	w1	MXHL	MXHLM
MXHL 206/C - MXHLM 206	G 1 1/4	G 1	500	166	167	16,8	16,8
MXHL 405/C - MXHLM 405	G 1 1/4	G 1	476	142	167	16,1	16,1
MXHL 406/A - MXHLM 406	G 1 1/4	G 1	500	166	167	18,2	18,5
MXHL 803/A - MXHLM 803	G 1 1/2	G 1	452	118	167	15,1	15,2
MXHL 804/A - MXHLM 804	G 1 1/2	G 1	482	148	167	17,3	17,6
MXHL 805/B - MXHLM 805	G 1 1/2	G 1	552	178	207	21,2	21,6

(1) Filling (2) Draining

Characteristic curves $n \approx 2800$ rpm

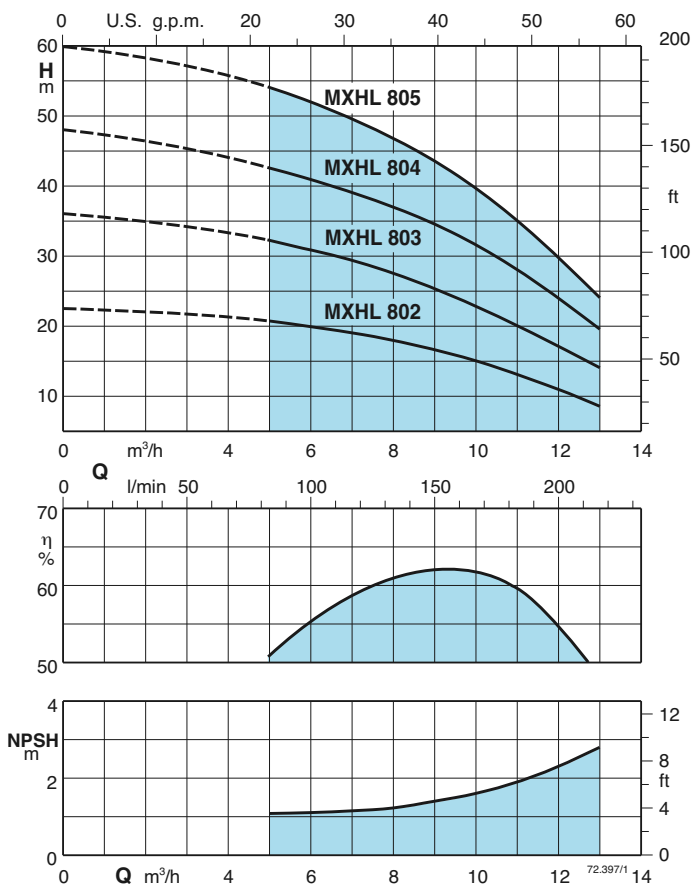
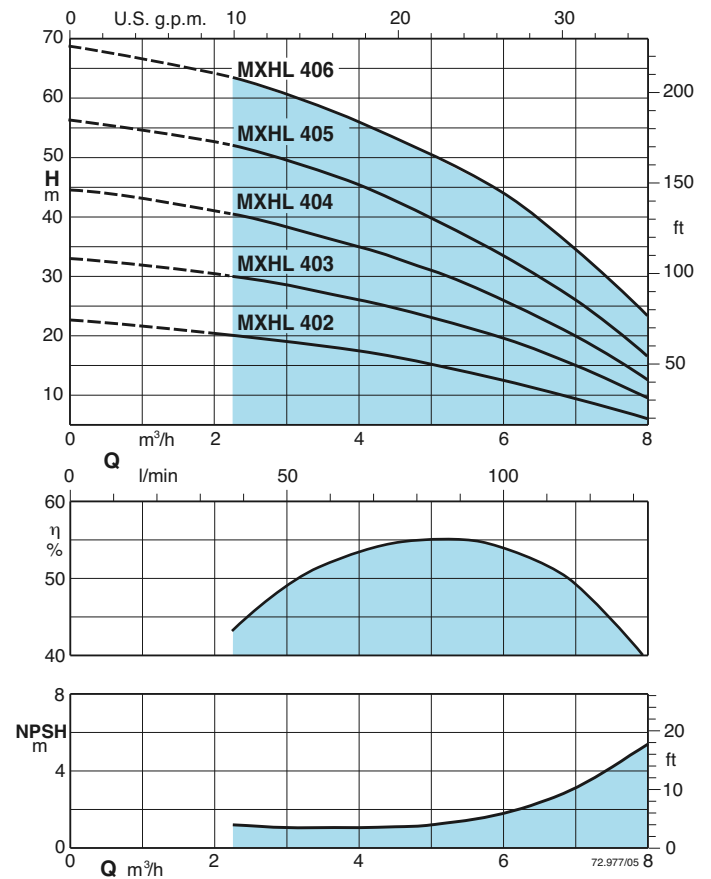
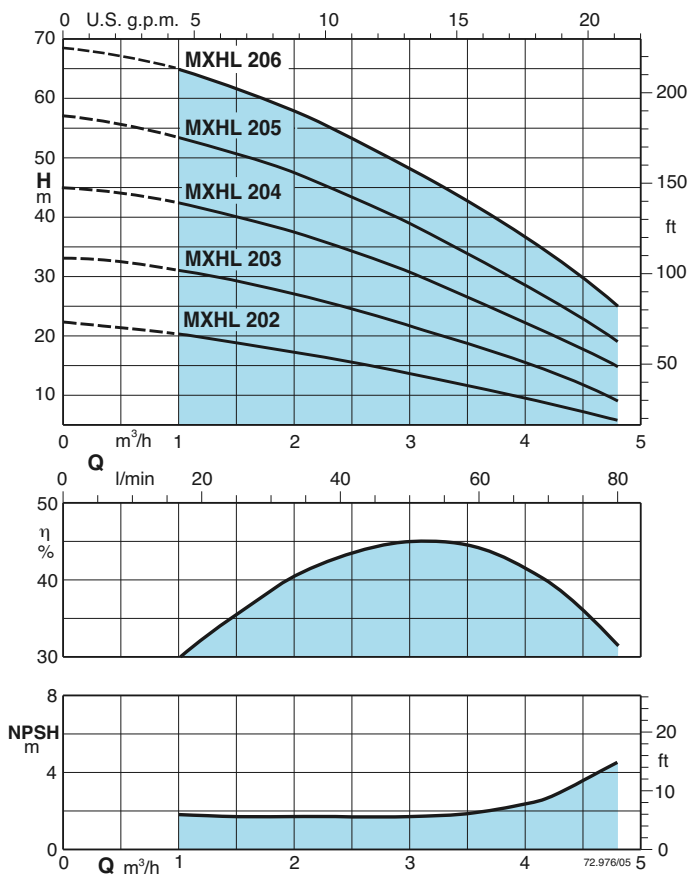



Construction

Horizontal multi-stage close coupled pumps in **chrome-nickel stainless steel**.

Compact and robust construction, with compact lantern bracket and motor with feet.

Single-piece barrel casing, with front suction port above pumps axis and radial delivery at top.

Filling and draining plugs on the middle of the pump, accessible from any side (like the terminal box).

Version with frequency converter (on request)

Applications

For water supply.

For clean liquids, without abrasives, which are non-aggressive for stainless steel (with suitable seal materials, on request).

Universal pump, for civil and industrial applications, for garden use and irrigation.

Operating conditions

Liquid temperature from - 15 °C to + 110 °C.

Ambient temperature up to 40 °C.

Maximum permissible pressure in the pump casing: 10 bar.

Motor

2-pole induction motor, 50 Hz ($n \approx 2900$ rpm).

MXH: three-phase 230/400 V $\pm 10\%$ up to 3 kW;

400/690 V $\pm 10\%$ from 4 to 7,5 kW.

Insulation class F. Protection IP 54.

Motor suitable for operation with frequency converter.

IE3 efficiency class for three-phase motors.

Constructed in accordance with: EN 60034-1;

EN 60034-30-1.

Special features on request

- Pump with Victaulic ports (MXH-V).

- Pump with flanged ports (MXH-F).

- Other voltages.

- Frequency 60 Hz (as per 60 Hz data sheet).

- Protection IP 55.

- Special mechanical seal

- Seal rings in FPM.

- Higher or lower ambient temperatures.

Materials

Component	Material
Pump casing	Chrome-nickel steel 1.4301 EN 10088 (AISI 304)
Stage casing	Chrome-nickel steel 1.4301 EN 10088 (AISI 304)
Wear ring	PPS
Impeller	Chrome-nickel steel 1.4301 EN 10088 (AISI 304)
Casing cover	Chrome-nickel steel 1.4301 EN 10088 (AISI 304)
Spacer sleeve	Chrome-nickel steel 1.4301 EN 10088 (AISI 304)
Pump shaft	Chrome-nickel steel 1.4401 EN 10088 (AISI 316)
Plug	Chrome-nickel steel 1.4305 EN 10088 (AISI 303)
Mechanical seal with seat according to ISO 3069-KU	Ceramic alumina, carbon, EPDM (Other materials on request)

Coverage chart $n \approx 2900$ rpm

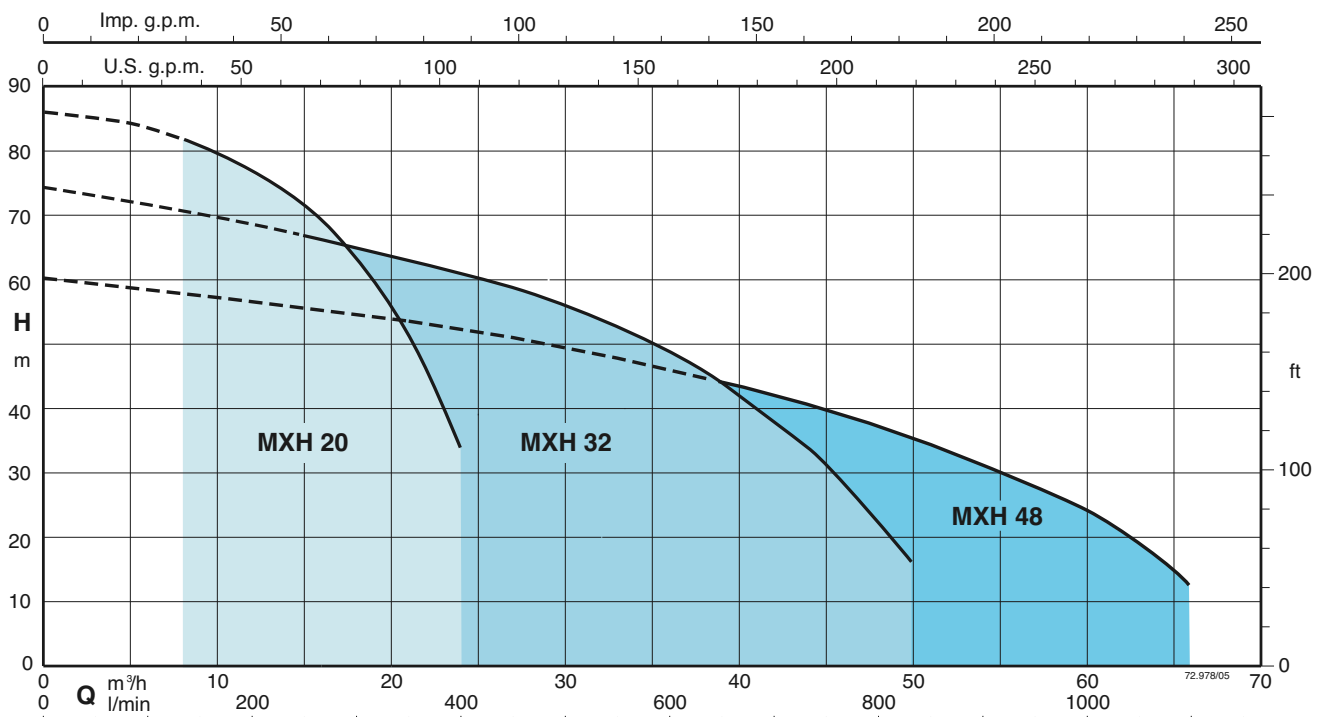

Pumps with frequency converter

The **MXH EI** pumps are available with power from 1,1 kW up to 7,5 kW, the pumps are equipped with **I-MAT** installed on board which allows to realize a variable-speed system extremely compact and efficient, ideal in applications of water supply and in the distribution of hot and cold water.

The pump is equipped with transducers suitable for operation and is already programmed at the factory.

Advantages

- Energy saving
- Compact design
- Easy to use
- Programmable to suit the system requirements
- Reliability

Costruction

The system comprises of:

- Pump
- Induction motor
- I-MAT Frequency converter
- Motor adapter for the motor mounting of the frequency converter
- Connection cable between frequency converter and induction motor
- Transducers

Main features

Rated motor power output from 1,1 kW to 7,5 kW

Control range from 1750 to 2900 rpm (2-pole)

Protection against dry running

Protection against operations with closed valve ports

Protection against system leakages

Protection against overcurrent in the motor

Protection against overvoltage and undervoltage of the power supply

Protection against current unbalances between phases

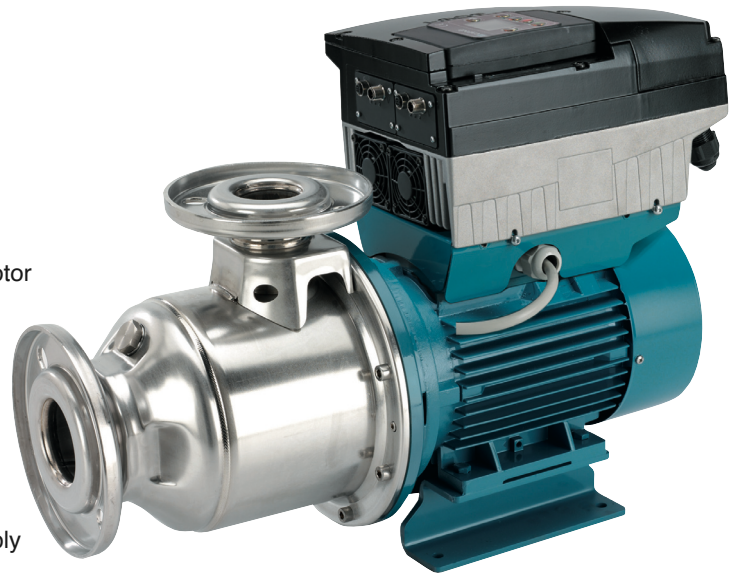

Operating modes



Constant pressure mode with pressure transducer

In this mode, the system maintains the preset pressure when the flow required by the installation changes.

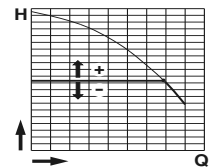

Proportional pressure mode with pressure transducer

In this mode the system changes the working pressure according to the required flow rate.

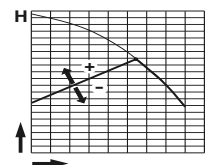

Constant flow mode with flow meter

In this mode the system maintains a constant flow rate value in a point of the installation according to the required pressure.

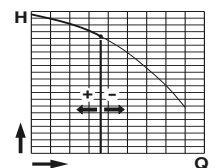

Fixed speed mode with setting of the speed preferential rotation.

In this mode, by changing the working frequency, you may choose any operational curve included within the working range.

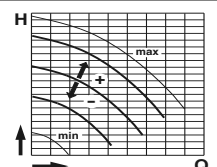

Constant temperature mode with temperature transducer

In this mode the system keeps the temperature constant inside a system by changing the speed of the pump.

Performance n ≈ 2900 rpm

3 ~	230 V		400 V		P ₂		Q	m ³ /h										
	A	A	kW	HP	kW	HP		0	8	10	12	14	16	18	20	22	24	
MXH 2001/A	4,6	2,7	1,1	1,5			H m	17,6	15,7	15,1	14,4	13,5	12,4	11,1	9,5	7,6	5,4	
MXH 2002/A	8,3	4,8	1,8	2,5				35,1	31,4	30,3	29,1	27,5	25,6	23,4	20,6	17,4	13,6	
MXH 2003	11,5	6,6	3	4				54	48,5	46,9	45,2	43,2	40,8	37,7	33,8	28,8	22,3	
MXH 2004/A	-	9,6	4	5,5				71,5	64,5	62,5	60,5	57,5	54,5	50	45	38	29	
MXH 2005	-	10,8	5,5	7,5				89	81,5	79	76	72,5	68	63	56,5	48,5	36	

3 ~	230 V		400 V		P ₂		Q	m ³ /h										
	A	A	kW	HP	kW	HP		0	15	21	24	27	30	33	36	39	44	50
MXH 3201/B	9,2	5,3	2,2	3			H m	18,4	16,3	15,3	14,8	14	13	12	10,8	9,3	6	-
MXH 3202/B	-	9,6	4	5,5				37	33	31	30	28,5	27	25	23	20,5	15	7,5
MXH 3203/A	-	10,8	5,5	7,5				55,5	50	47	45,5	43	40,5	38	35	31	23	10
MXH 3204/A	-	14,3	7,5	10				74,5	67	63	61	59	56	53	49	44	34	16,5

3 ~	230 V		400 V		P ₂		Q	m ³ /h										
	A	A	kW	HP	kW	HP		0	21	27	33	39	45	48	51	54	60	66
MXH 4801/A	11,5	6,6	3	4			H m	20	18	17	16	14,5	12,5	11,5	10,5	9,5	7	-
MXH 4802/A	-	10,8	5,5	7,5				41	35,3	33	30,5	27,5	24,5	22,5	21	19	14	7,5
MXH 4803/A	-	14,3	7,5	10				60,5	53	50	46	42,5	38	35	32,5	29	22,5	16

P₂ Rated motor power output.

Test results with clean cold water, without gas content.

+ 0,5 m security margin on NPSH-value is necessary.

Tolerances according to UNI EN ISO 9906:2012

Dimensions and weights

Threaded ports MXH

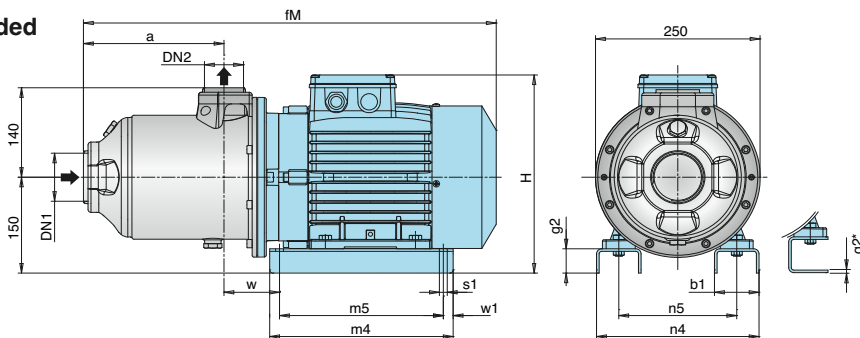

TYPE	DN1 ISO 228	DN2 ISO 228	mm											kg	
			fM	a	H	m4	m5	n4	n5	w1	b1	s1	w		g2
MXH 2001/A	G 2	G 1 1/2	467	127	280	205	175	170	130	15	54	10	95	6*	26
MXH 2002/A	G 2	G 1 1/2	507	127	280	205	175	170	130	15	54	10	95	6*	30
MXH 2003	G 2	G 1 1/2	540	146	290	205	175	180	140	15	54	10	112	6*	38
MXH 2004/A	G 2	G 1 1/2	574	180,5	290	205	175	180	140	15	54	10	112	6*	39
MXH 2005	G 2	G 1 1/2	630,5	215	310	280	250	258	190	15	68	12	84	38	50,5
MXH 3201/B	G 2 1/2	G 2	503,5	123	280	205	175	170	130	15	54	10	95	6*	29,4
MXH 3202/B	G 2 1/2	G 2	517,5	123	290	205	175	180	140	15	54	10	112	6*	38,5
MXH 3203/A	G 2 1/2	G 2	584,5	169	310	280	250	258	190	15	68	12	84	38	50
MXH 3204/A	G 2 1/2	G 2	630,5	215	310	280	250	258	190	15	68	12	84	38	57,5
MXH 4801/A	G 3	G 2 1/2	547,5	138,5	290	205	175	180	140	15	54	10	128,5	6*	38
MXH 4802/A	G 3	G 2 1/2	568,5	138,5	310	280	250	258	190	15	68	12	100	38	49,5
MXH 4803/A	G 3	G 2 1/2	630,5	200	310	280	250	258	190	15	68	12	100	38	58

Flanges* EN 1092-2

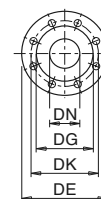

DN	DE	DK	DG	Holes	
				N.	Ø
40	150	110	81	4	19
50	165	125	99	4	19
65	185	145	118	4	19
80	200	160	132	8	19

* ASME 150 lb (ex ANSI 150 lb)

Victaulic ports MXH-V

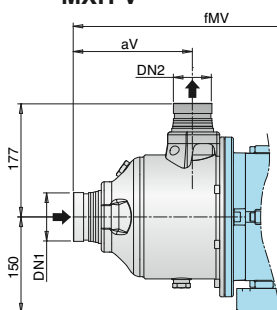

TYPE	DN1 mm	DN2 mm	mm	
			fMV	aV
MXH-V 3201/B	76,1 (DN65)	60,3 (DN50)	541	160
MXH-V 3202/B	76,1 (DN65)	60,3 (DN50)	555	160
MXH-V 3203/A	76,1 (DN65)	60,3 (DN50)	622	206
MXH-V 3204/A	76,1 (DN65)	60,3 (DN50)	668	252
MXH-V 4801/A	88,9 (DN80)	76,1 (DN65)	585	175
MXH-V 4802/A	88,9 (DN80)	76,1 (DN65)	606	175
MXH-V 4803/A	88,9 (DN80)	76,1 (DN65)	668	237

Flanged ports MXH-F

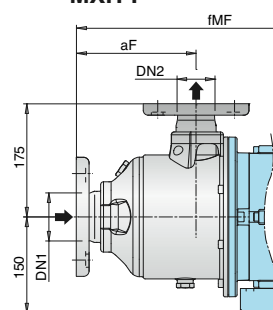

TYPE	DN1 mm	DN2 mm	mm	
			fMF	aF
MXH-F 2001/A	50	40	502	161,5
MXH-F 2002/A	50	40	542	161,5
MXH-F 2003	50	40	575	180,5
MXH-F 2004/A	50	40	624	215
MXH-F 2005	50	40	665	249,5
MXH-F 3201/B	65	50	531	151
MXH-F 3202/B	65	50	545	151
MXH-F 3203/A	65	50	612	197
MXH-F 3204/A	65	50	658	243
MXH-F 4801/A	80	65	565	156
MXH-F 4802/A	80	65	586	156
MXH-F 4803/A	80	65	648	218

Dimensions and weights

Threaded ports MXH EI

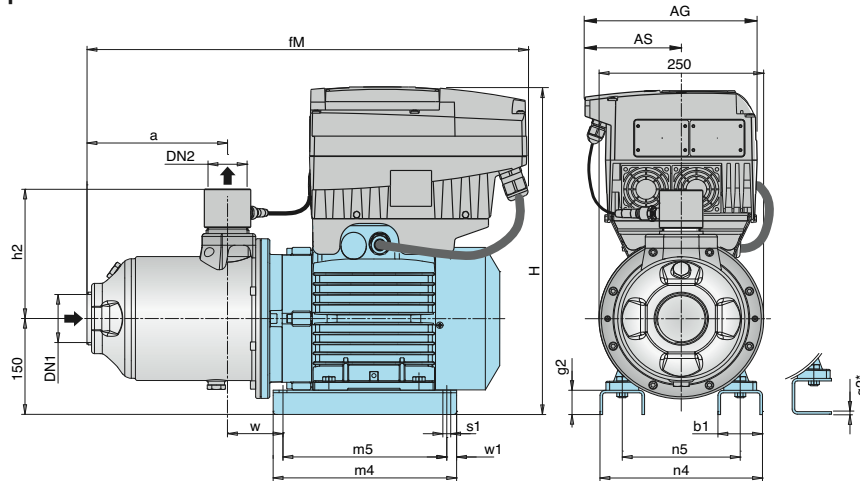

TYPE	DN1 ISO 228	DN2 ISO 228	mm																kg
			fM	AG	AS	a	H	h2	m4	m5	n4	n5	w1	b1	s1	w	g2		
MXH EI 2002/A	G 2	G 1 1/2	532	210	118	127	436	192	205	175	170	130	15	54	10	95	6*	36,4	
MXH EI 2003	G 2	G 1 1/2	572	210	118	146	444	192	205	175	180	140	15	54	10	112	6*	45,5	
MXH EI 2004/A	G 2	G 1 1/2	606	210	118	180,5	444	192	205	175	180	140	15	54	10	112	6*	46,5	
MXH EI 2005	G 2	G 1 1/2	630,5	210	118	215	472	192	280	250	258	190	15	68	12	84	38	65,3	
MXH EI 3202/B	G 2 1/2	G 2	594,5	210	118	123	444	197	205	175	180	140	15	54	10	112	6*	46,0	
MXH EI 3203/A	G 2 1/2	G 2	594,5	210	118	169	472	197	280	250	258	190	15	68	12	84	38	64,8	
MXH EI 3204/A	G 2 1/2	G 2	665,5	281	153	215	518	197	280	250	258	190	15	68	12	84	38	72,3	
MXH EI 4802/A	G 3	G 2 1/2	568,5	210	118	138,5	472	202	280	250	258	190	15	68	12	100	38	64,3	
MXH EI 4803/A	G 3	G 2 1/2	665,5	281	153	200	518	202	280	250	258	190	15	68	12	100	38	72,8	

Flanged ports MXH-F EI

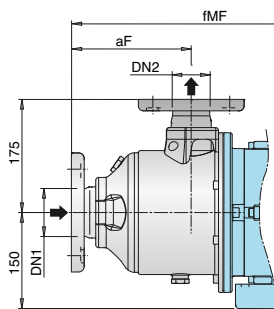

TYPE	DN1 mm	DN2 mm	mm	
			fMF	aF
MXH-F EI 2002/A	50	40	567	161,5
MXH-F EI 2003	50	40	607	180,5
MXH-F EI 2004/A	50	40	641	215
MXH-F EI 2005	50	40	665	249,5
MXH-F EI 3202/B	65	50	622	151
MXH-F EI 3203/A	65	50	622	197
MXH-F EI 3204/A	65	50	693	243
MXH-F EI 4802/A	80	65	586	156
MXH-F EI 4803/A	80	65	683	218

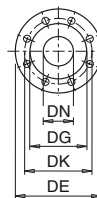

Flanges* EN 1092-2

DN	DE	DK	DG	Holes	
				N.	Ø
40	150	110	81	4	19
50	165	125	99	4	19
65	185	145	118	4	19
80	200	160	132	8	19

* ASME 150 lb (ex ANSI 150 lb)

Characteristic curves $n \approx 2900$ rpm

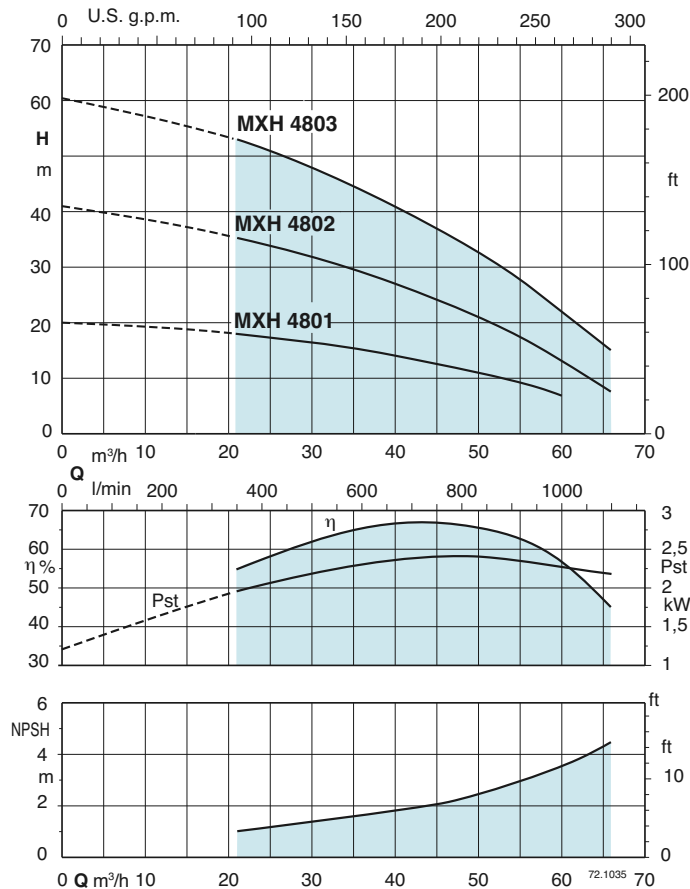
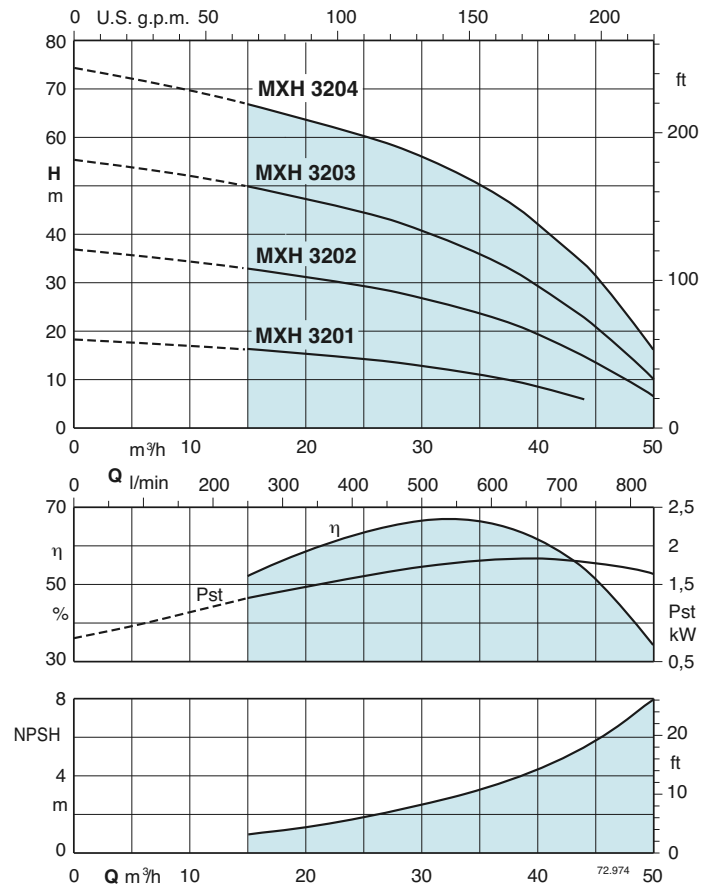
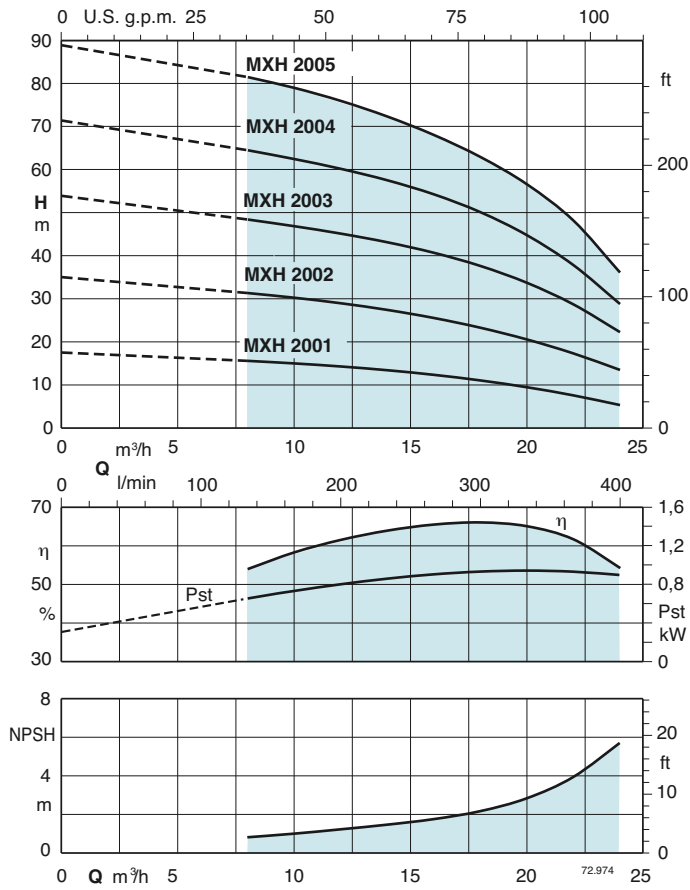

Designation

MXH-F EI 3204 *

- Series _____
- No code = threaded ports _____
- Victaulic ports _____ V
- Flanged ports _____ F
- With frequency converter I-MAT _____
- Rated capacity in m^3/h _____
- Number of stages _____

Construction variants

- special seal code (no code = standard seal) _____

Features

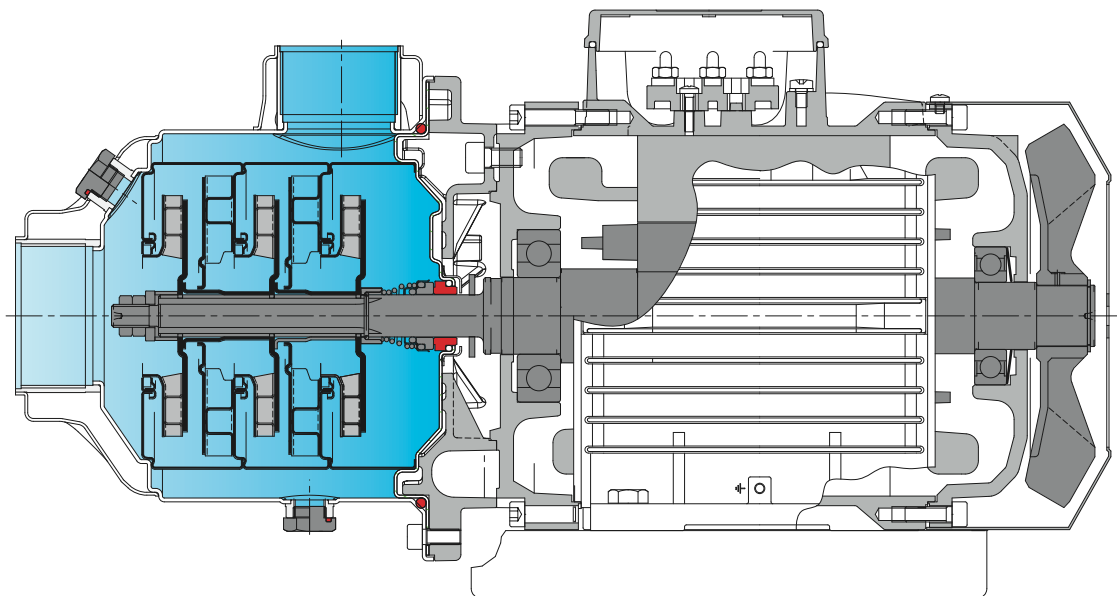

Flexibility

Three versions of ports: threaded, flanged and Victaulic.

Extra safety

With front axis suction port for optimum suction conditions.

Reliable

All hydraulic parts in contact with the pumped liquid are made in stainless steel.
For liquids from -15 °C to 110 °C.

Robust

Single-piece, thick barrel casing, open on one side only, with reinforced threaded ports.

Compact

The bracket between pump and motor is extremely compact.

Greater protection

Against leakage, with the pump casing cover separated from the motor shield.
Possibility of inspecting the seal through the side apertures between the two walls.