



**GMV**



Submersible pumps with vortex impeller in cast iron EN-GJL-250 pag. 250

**GMVS**



Submersible pumps with vortex impeller in cast iron with polyurethane coating pag. 257

**GMC**

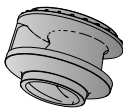

Submersible pumps with single channel impeller in cast iron EN-GJL-250 pag. 259

**GMN**



Submersible pumps with channels impeller in cast iron EN-GJL-250 pag. 268

**GMG**



Submersible pumps with grinder in cast iron EN-GJL-250 pag. 282

**I-GMV**



Submersible pumps with vortex impeller in stainless steel AISI316 pag. 286

**I-GMC**



Submersible pumps with single channel impeller in stainless steel AISI316 pag. 286

**I-GMN**



Submersible pumps with channels impeller in stainless steel AISI316 pag. 286

**B-GMV**



Submersible pumps with vortex impeller in Marine Bronze B10 pag. 297

**B-GMC**

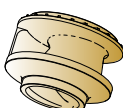

Submersible pumps with single channel impeller in Marine Bronze B10 pag. 297

**B-GMN**



Submersible pumps with channels impeller in Marine Bronze B10 pag. 297

A new series of submersible pumps with high efficiency hydraulics designed to move slurry, sewage and industrial process fluids.

The range covers a wide field of use with head up to 75 m And flows up to 2300 m<sup>3</sup>/h, with a maximum solid passage up to 140 mm keeping the risk of blockage to a minimum. Dimensionally designed for heavy demand, even on critical applications.

Explosion proof version on request.

### Pump designation

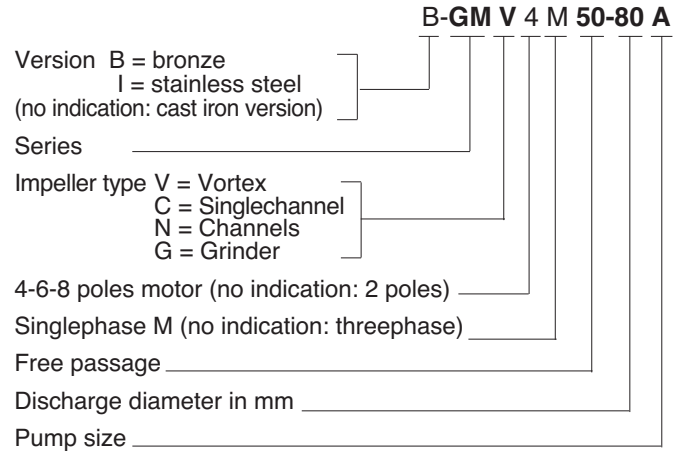

### Coverage chart

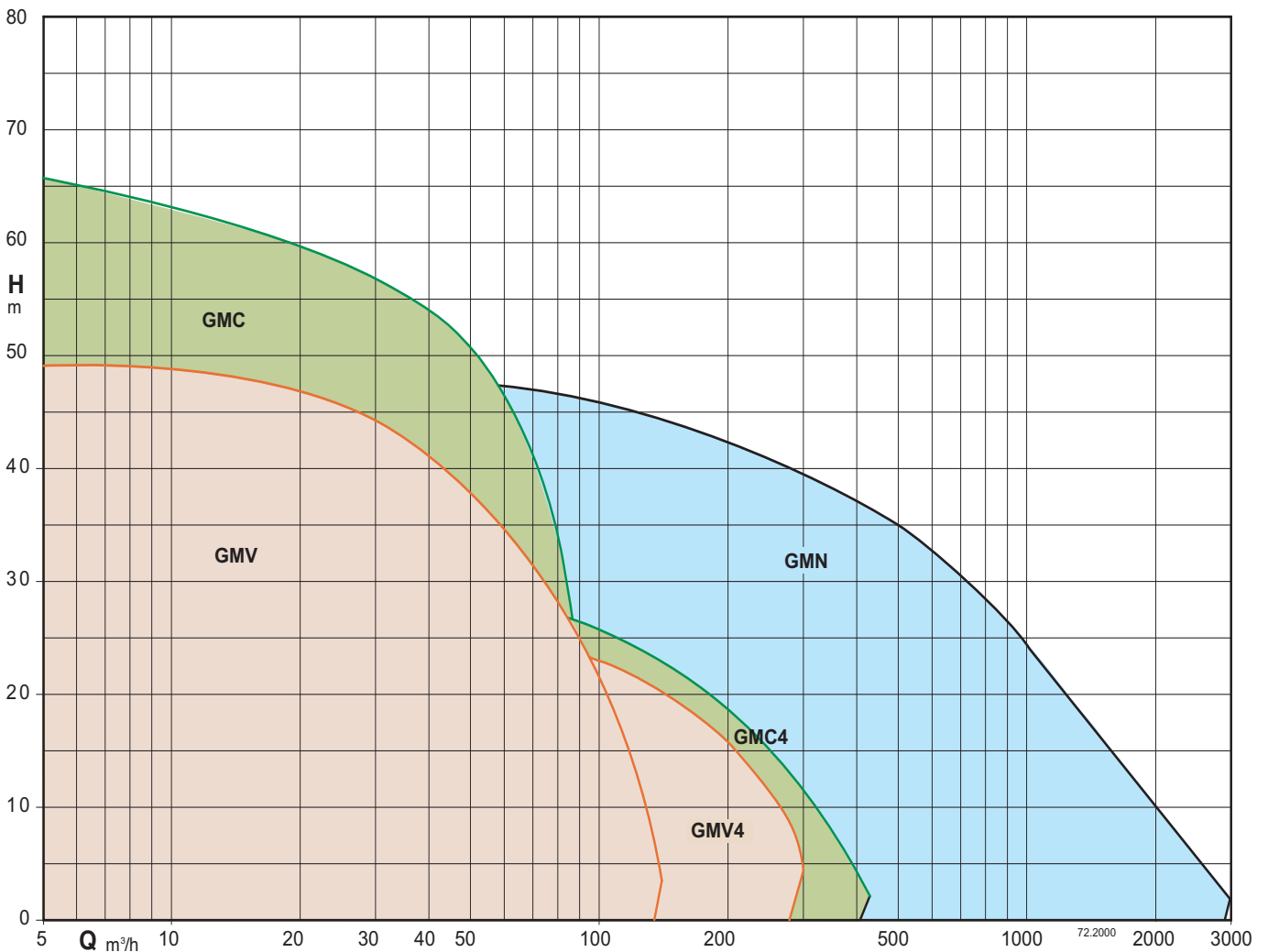

Tolerances according to ISO 9906, annex A.



### Construction

Submersible pumps with channels impeller.  
Twin mechanical seal with oil chamber.  
Delivery connection DN 65-80-100-150-200-250-300.

### Applications

Suitable to pump slurry, sewage and waste water (non-corrosive) with solids in suspension.  
For industrial and residential installations and general drainage applications.  
They are ideal for applications with smaller solids.  
Solid passage from 30 to 140 mm

### Operating conditions

Liquid temperature up to 40 °C.  
Maximum immersion depth: 20 m (with suitable cable length).  
Continuous duty (with pump immersed at minimum level).

### Main materials

Pump casing: cast iron EN-GJL-250  
Impeller: cast iron EN-GJL-250+Ni  
Motor casing: cast iron EN-GJL-250  
Motor cover: cast iron EN-GJL-250  
Shaft: stainless steel AISI 420B  
Mechanical seal motor side: graphite/ceramic  
Mechanical seal pump side: silicon carbide/silicon carbide

### Motor

2-4-6 or 8 poles induction, 50Hz  
Three-phase version: 400V ± 10%, up to 3,2 kW  
400/690V ± 10%, over 3,2 kW  
Insulation class: H  
Protection degree: IP 68  
N° of starting x hour: max 15 with regular intervals  
Cable: H07RN-F, length 10 m  
Other models: contact our sale office

### Coverage chart

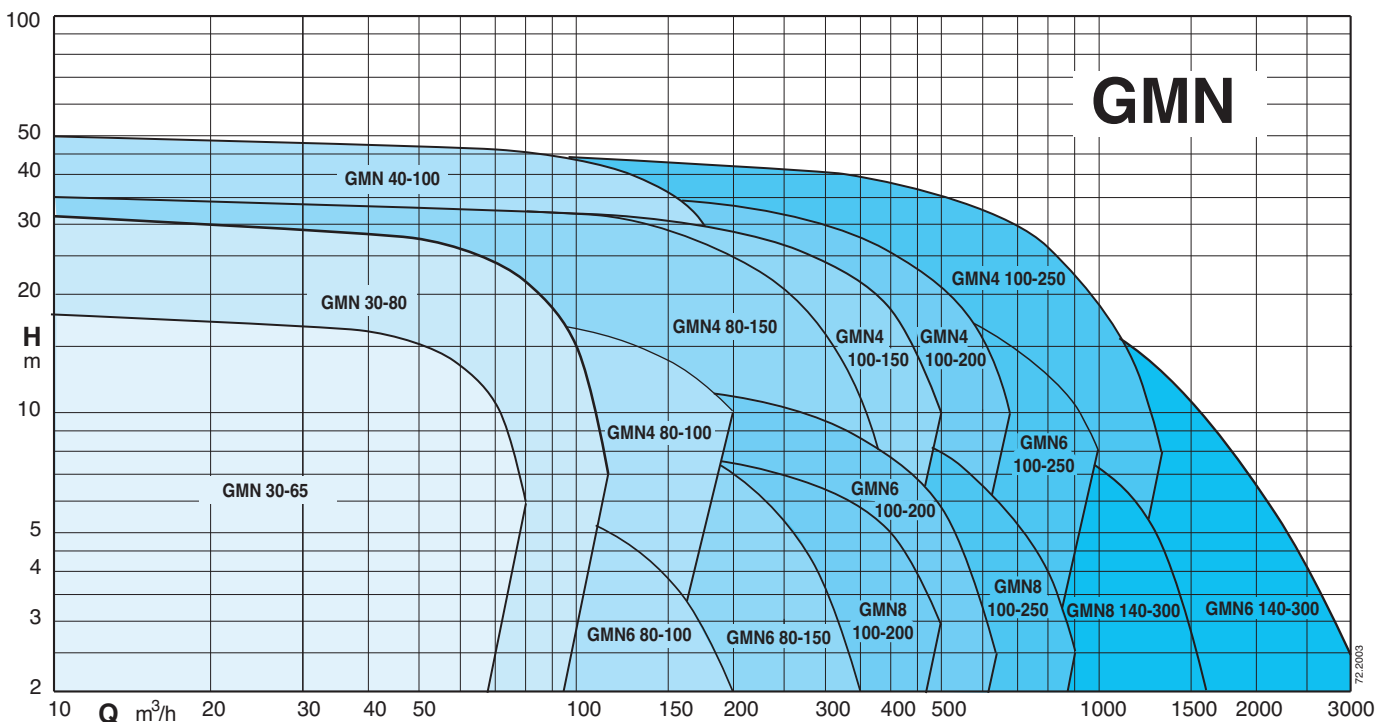

**Technical data**

TYPE	P <sub>2</sub> kW	I <sub>N</sub> A	Power Supply	r.p.m.	Starting	DN mm	Free passage Ø mm	Thermal protector	Humidity probe	ATEX Eex
GMN 30-65B	3,2	6,5	3~ 400V	2850	D.O.L.	65	30	NO	NO	✓
GMN 30-65A	3,2	6,5	3~ 400V	2850	D.O.L.	65	30	NO	NO	✓
GMN 30-80B	5,7	12,5	3~ 400/690V	2850	Y/Δ	80	30	●	●	✓
GMN 30-80A	5,7	12,5	3~ 400/690V	2850	Y/Δ	80	30	●	●	✓
GMN 30-80S	8,2	15,5	3~ 400/690V	2850	Y/Δ	80	30	●	●	
GMN 40-100D	13,8	29,5	3~ 400/690V	2850	Y/Δ	100	40	●	●	✓
GMN 40-100C	13,8	29,5	3~ 400/690V	2850	Y/Δ	100	40	●	●	✓
GMN 40-100B	18,2	34	3~ 400/690V	2850	Y/Δ	100	40	●	●	✓
GMN 40-100S	22,4	40,1	3~ 400/690V	2850	Y/Δ	100	40	●	●	
GMN4 80-100D	4,6	9,5	3~ 400/690V	1450	Y/Δ	100	80	●	●	✓
GMN4 80-100C	7,1	13,5	3~ 400/690V	1450	Y/Δ	100	80	●	●	✓
GMN4 80-100A	11,6	23,2	3~ 400/690V	1450	Y/Δ	100	80	●	●	✓
GMN6 80-100B	2,3	6	3~ 400V	950	D.O.L.	100	80	NO	NO	✓
GMN6 80-100A	2,8	6,6	3~ 400V	950	D.O.L.	100	80	NO	NO	✓
GMN6 80-150B	5,2	12,5	3~ 400/690V	950	Y/Δ	150	80	●	●	✓
GMN6 80-150A	6,4	16	3~ 400/690V	950	Y/Δ	150	80	●	●	✓
GMN6 100-150B/A	16	34,2	3~ 400/690V	950	Y/Δ	150	100	●	●	
GMN6 100-150A/A	16	34,2	3~ 400/690V	950	Y/Δ	150	100	●	●	
GMN4 80-150C/A	27	52,2	3~ 400/690V	1450	Y/Δ	150	80	●	●	
GMN4 80-150B/A	35,7	65,5	3~ 400/690V	1450	Y/Δ	150	80	●	●	
GMN4 100-150G	20,7	41,5	3~ 400/690V	1450	Y/Δ	150	100	●	●	
GMN4 100-150F	25,4	48,5	3~ 400/690V	1450	Y/Δ	150	100	●	●	
GMN4 100-150E/A	26,1	51	3~ 400/690V	1450	Y/Δ	150	100	●	●	
GMN4 100-150D/A	35,7	65,5	3~ 400/690V	1450	Y/Δ	150	100	●	●	
GMN4 100-150S/A	35,7	65,5	3~ 400/690V	1450	Y/Δ	150	100	●	●	
GMN4 100-200C	46	83,5	3~ 400/690V	1450	Y/Δ	200	100	●	●	
GMN4 100-200B	52,1	92,5	3~ 400/690V	1450	Y/Δ	200	100	●	●	
GMN4 100-200A	52,1	92,5	3~ 400/690V	1450	Y/Δ	200	100	●	●	
GMN4 100-250D	77,2	135	3~ 400/690V	1450	Y/Δ	250	100	●	●	
GMN4 100-250C	77,2	135	3~ 400/690V	1450	Y/Δ	250	100	●	●	
GMN4 100-250B	79,5	135	3~ 400/690V	1450	Y/Δ	250	100	●	●	
GMN4 100-250A	79,5	135	3~ 400/690V	1450	Y/Δ	250	100	●	●	
GMN6 100-200F/A	16	34,2	3~ 400/690V	950	Y/Δ	200	100	●	●	
GMN6 100-200E/A	16	34,2	3~ 400/690V	950	Y/Δ	200	100	●	●	
GMN6 100-200D/A	16	34,2	3~ 400/690V	950	Y/Δ	200	100	●	●	
GMN6 100-250D	23,4	45,5	3~ 400/690V	950	Y/Δ	250	100	●	●	
GMN6 100-250C	29	57	3~ 400/690V	950	Y/Δ	250	100	●	●	
GMN6 100-250B	40	80	3~ 400/690V	950	Y/Δ	250	100	●	●	
GMN6 100-250A	40	80	3~ 400/690V	950	Y/Δ	250	100	●	●	
GMN6 140-300D	32	60,5	3~ 400/690V	950	Y/Δ	300	140	●	●	
GMN6 140-300C	40	80	3~ 400/690V	950	Y/Δ	300	140	●	●	
GMN6 140-300B	55,8	108	3~ 400/690V	950	Y/Δ	300	140	●	●	
GMN6 140-300A	55,8	108	3~ 400/690V	950	Y/Δ	300	140	●	●	
GMN8 100-200B/B	9,6	20	3~ 400/690V	750	Y/Δ	200	100	●	●	
GMN8 100-200A	9,6	20	3~ 400/690V	750	Y/Δ	200	100	●	●	
GMN8 100-250B/A	13,7	29,5	3~ 400/690V	750	Y/Δ	250	100	●	●	
GMN8 100-250A/B	21,8	47,5	3~ 400/690V	750	Y/Δ	250	100	●	●	
GMN8 140-300A	26,7	59	3~ 400/690V	750	Y/Δ	300	140	●	●	

 P<sub>2</sub> Rated power output

 I<sub>N</sub> Rated current

● Standard

✓ ATEX Eex Version on demand

## Characteristic curves

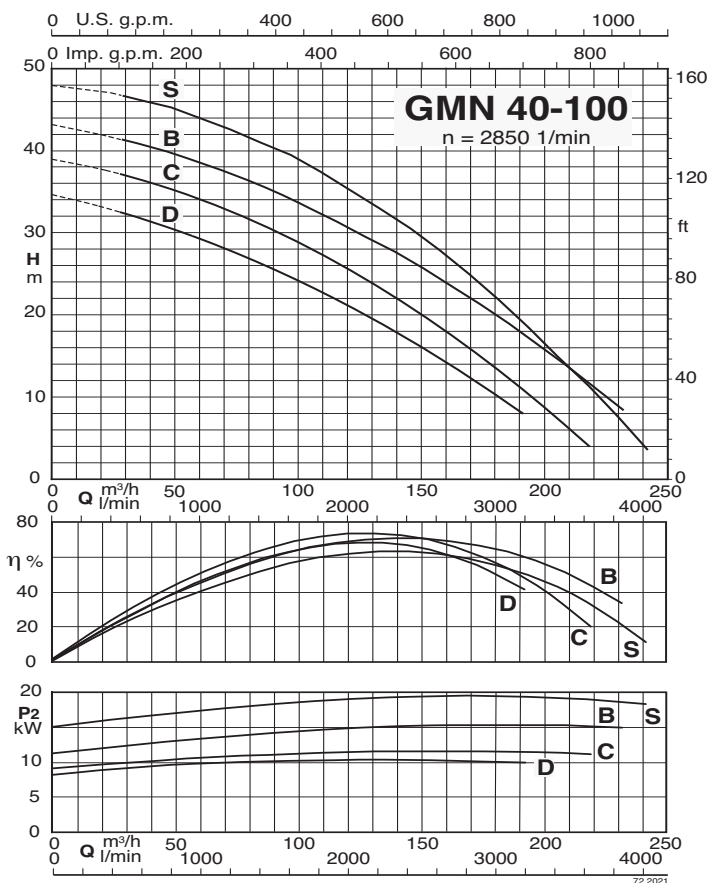
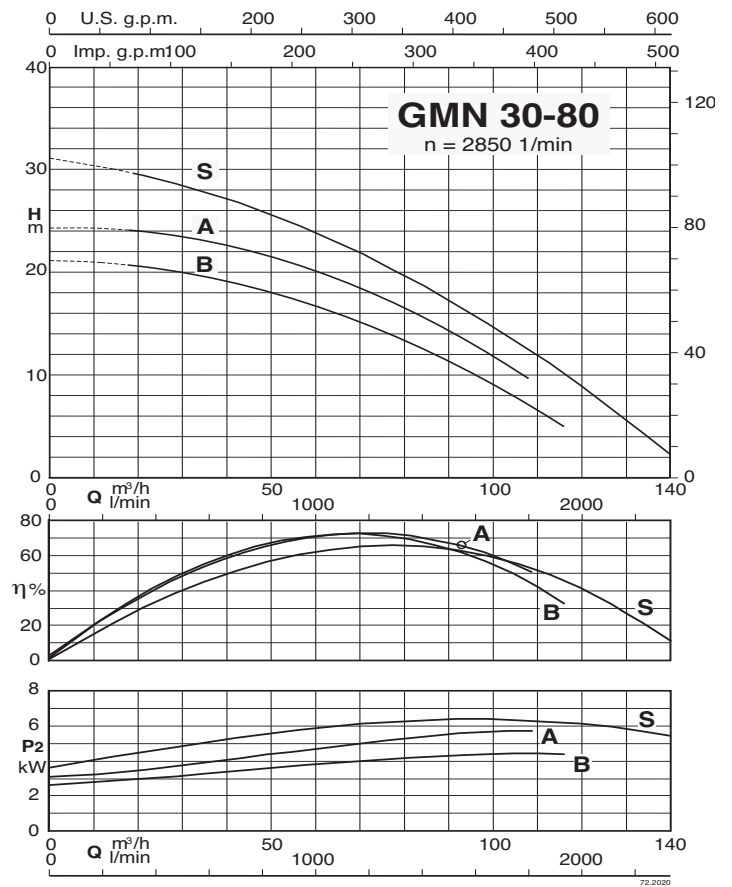
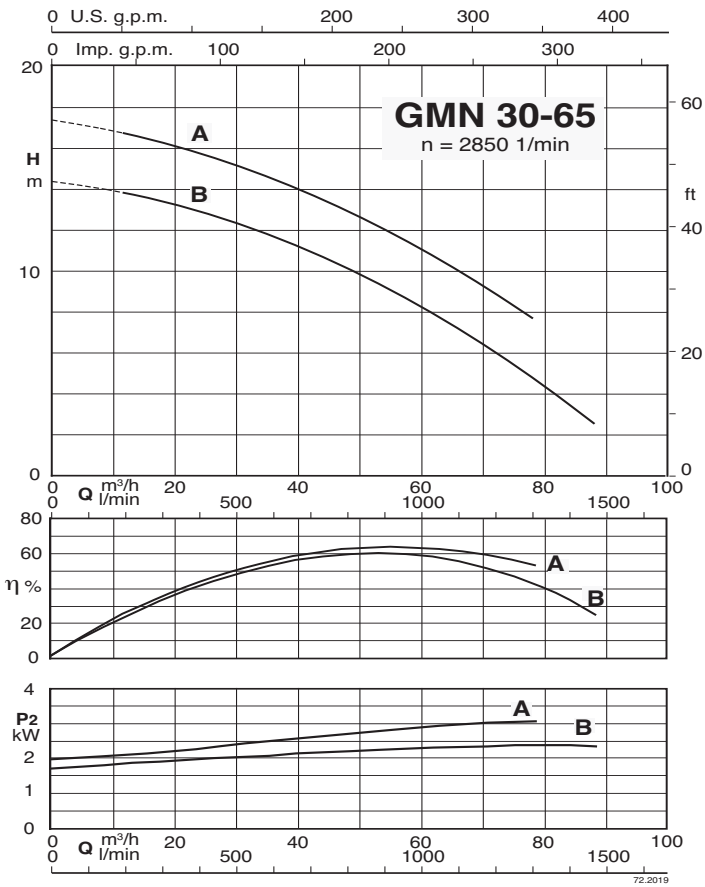

## Characteristic curves

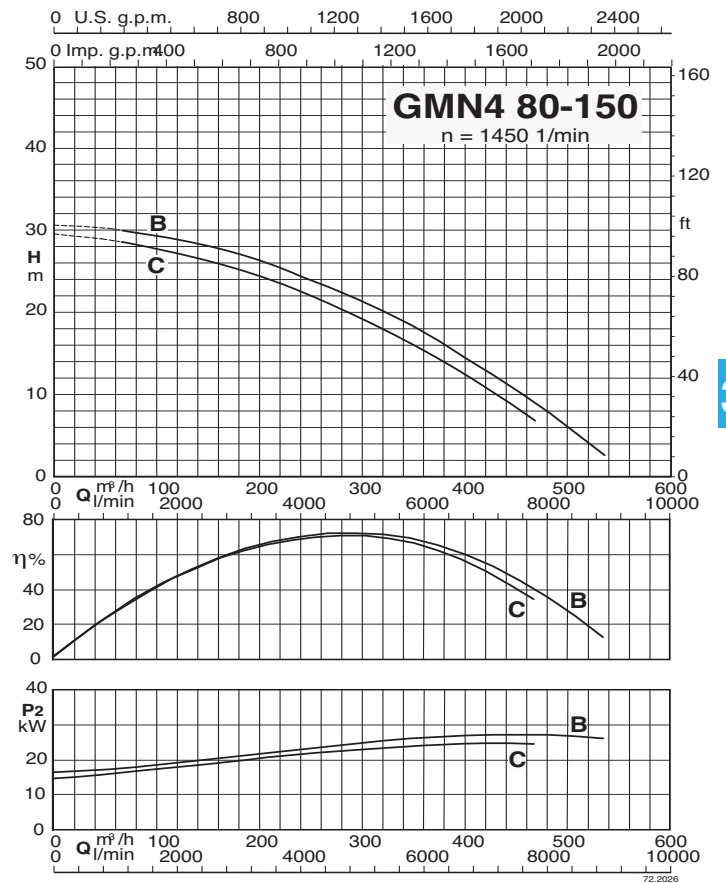
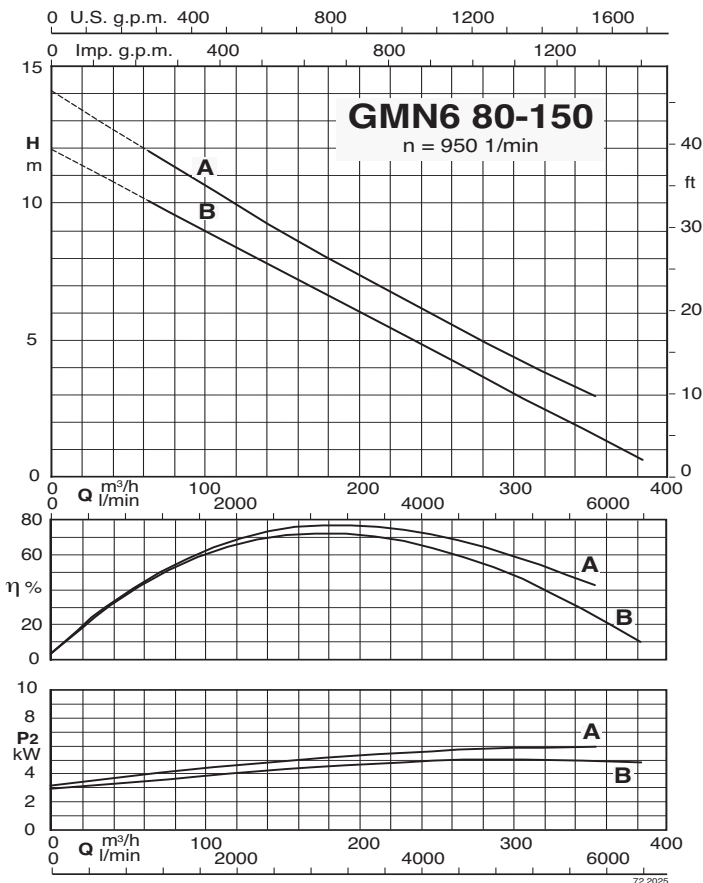
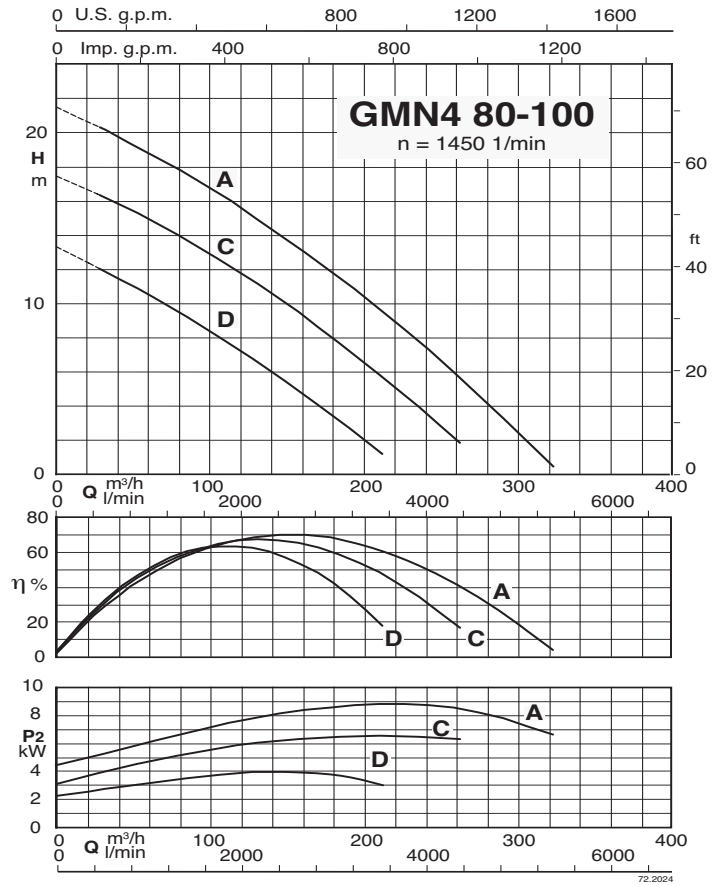
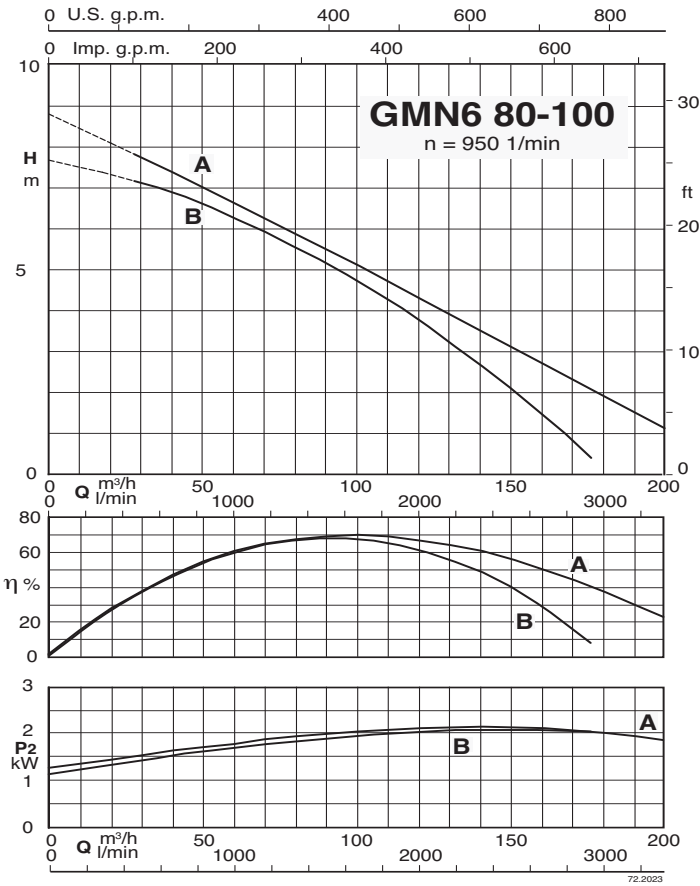



## Characteristic curves

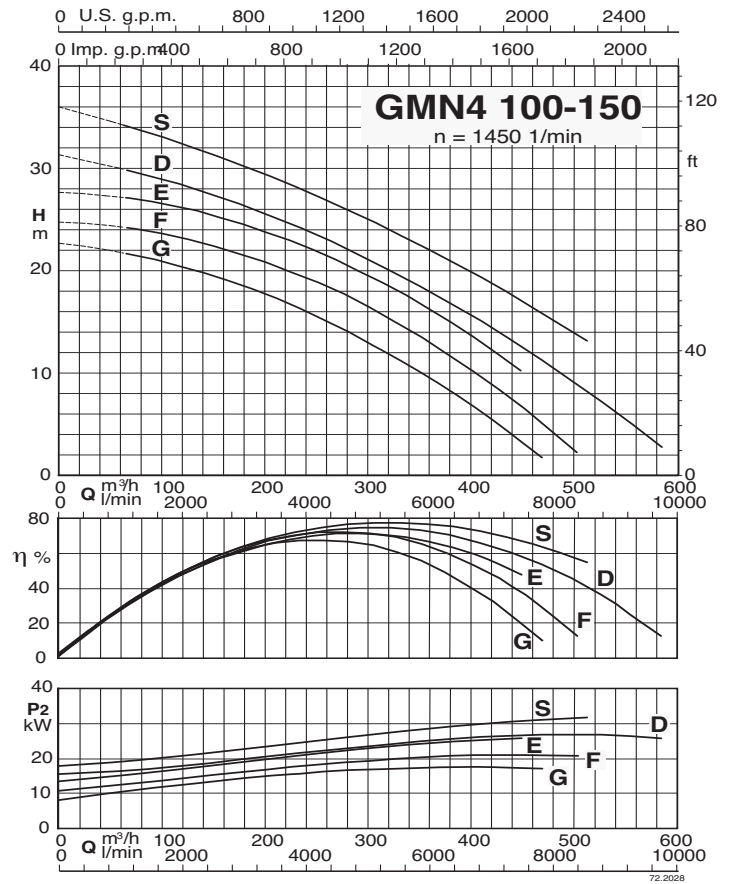
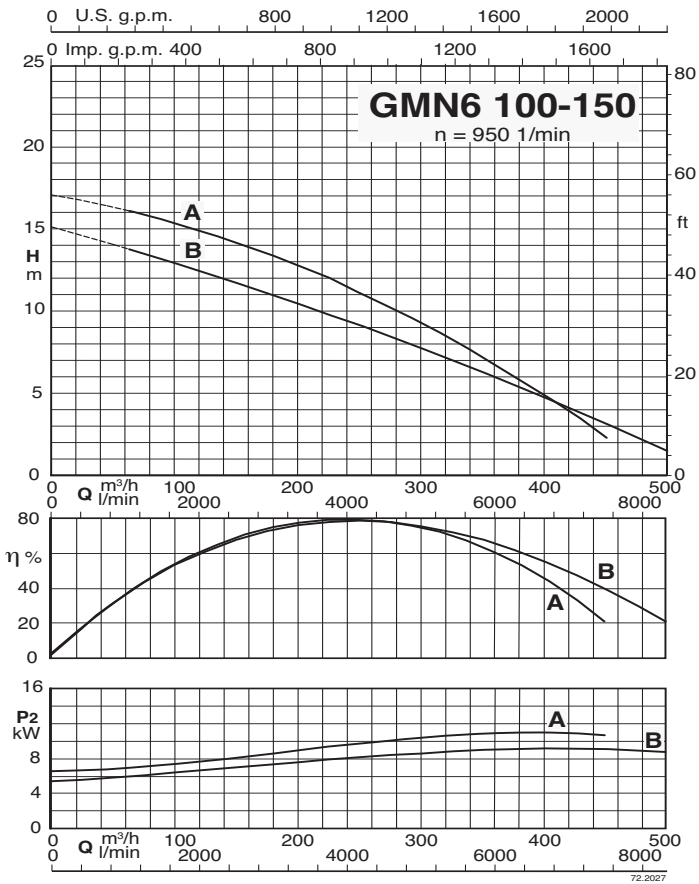



### Characteristic curves

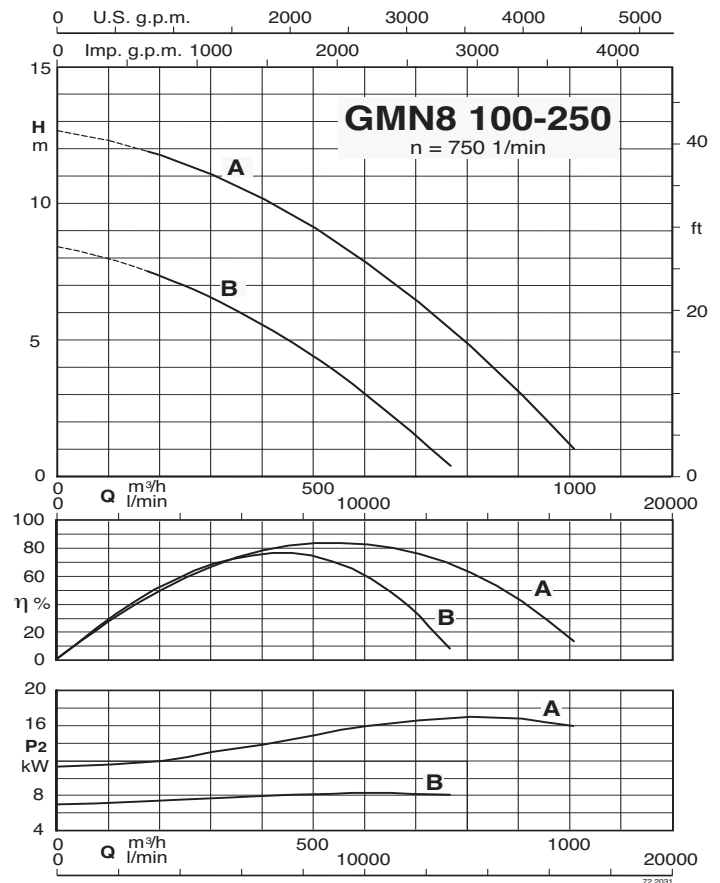
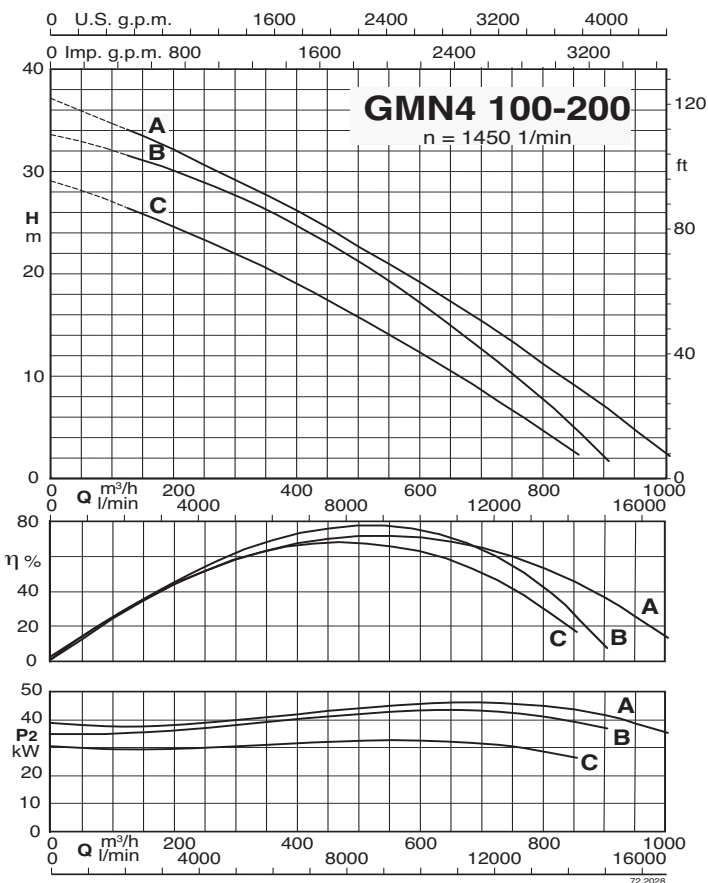
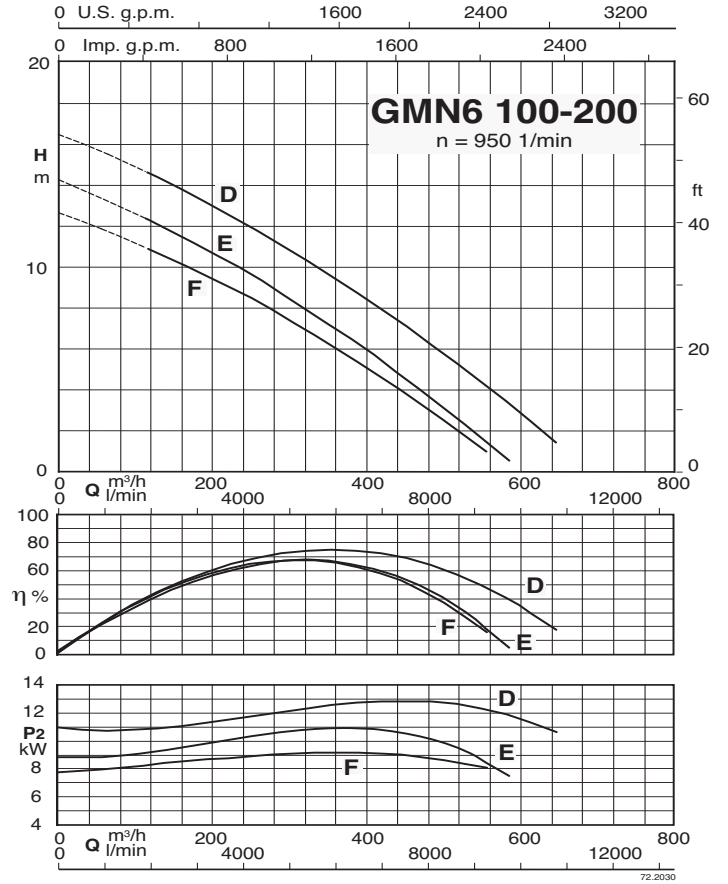
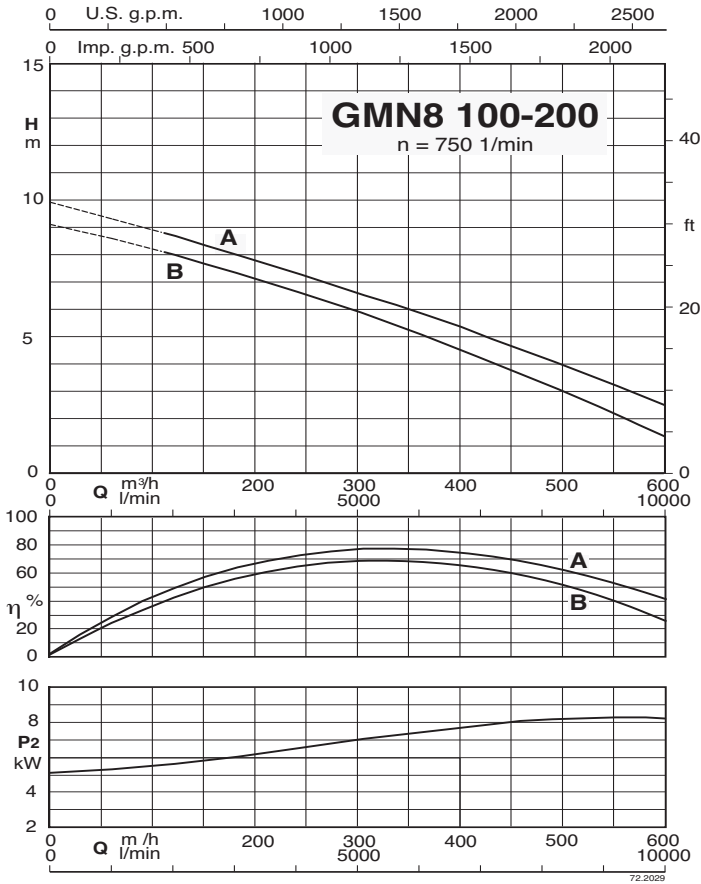

## Characteristic curves

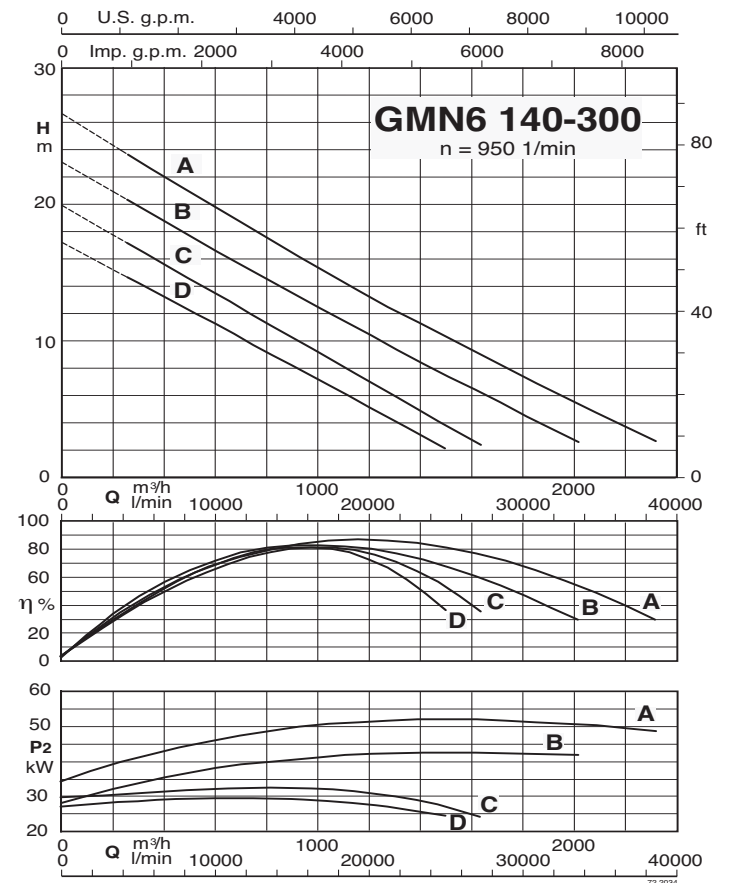
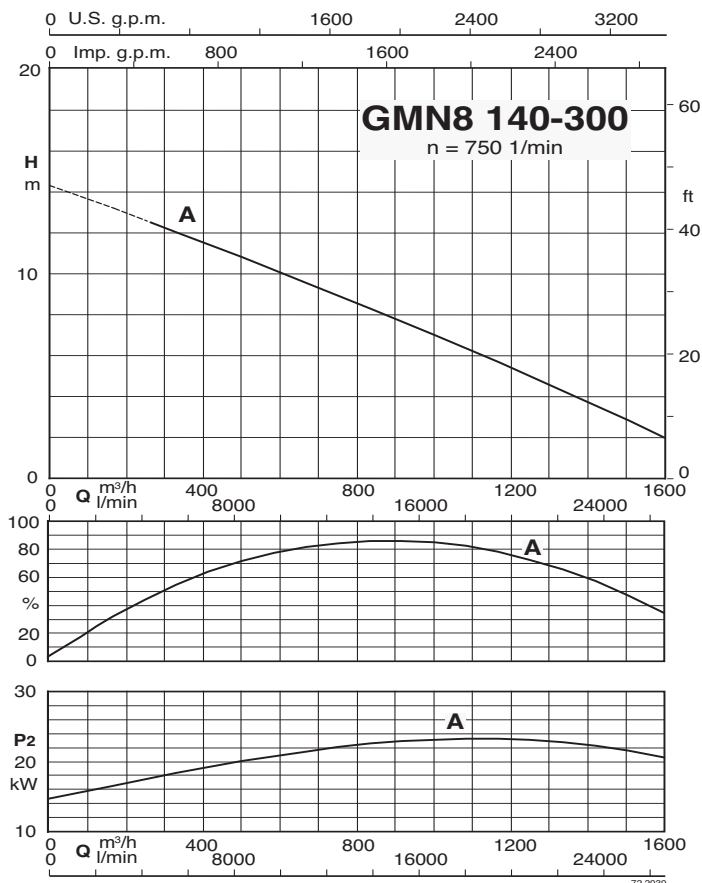
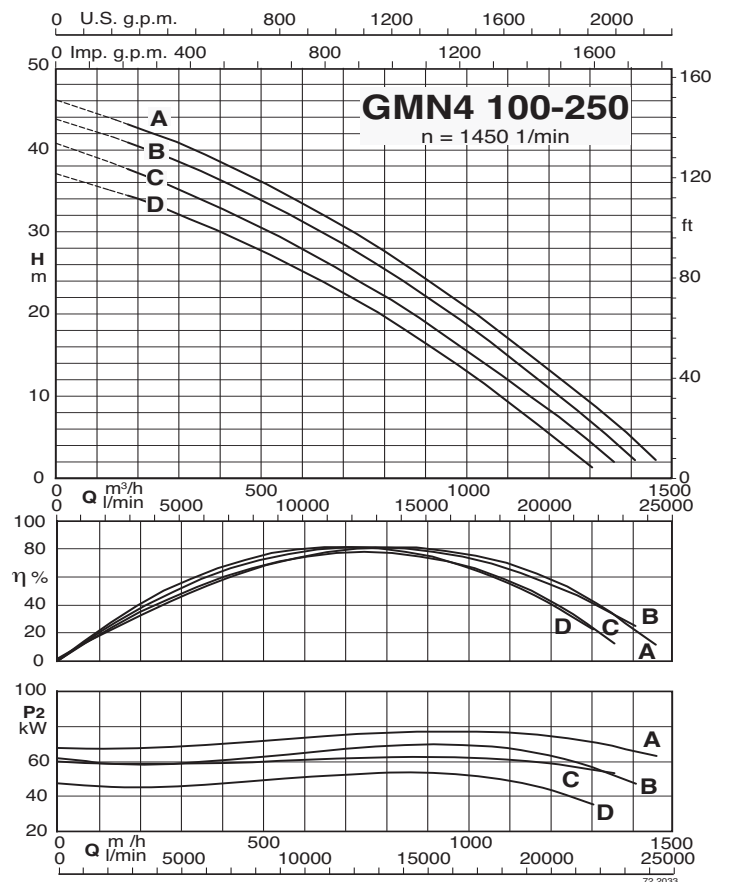
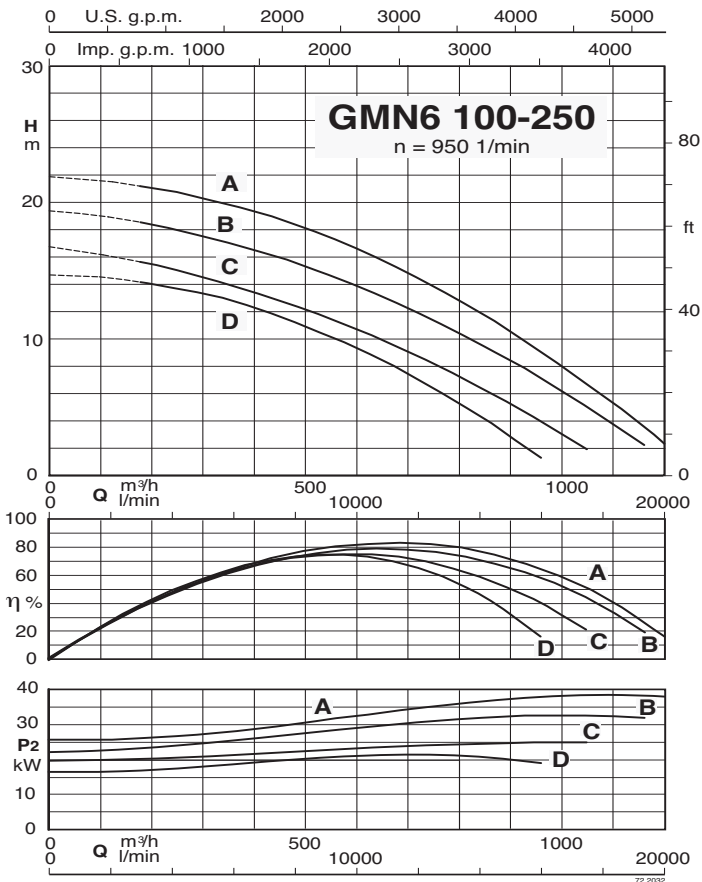

### Dimensions and weights

#### GMN 30-65

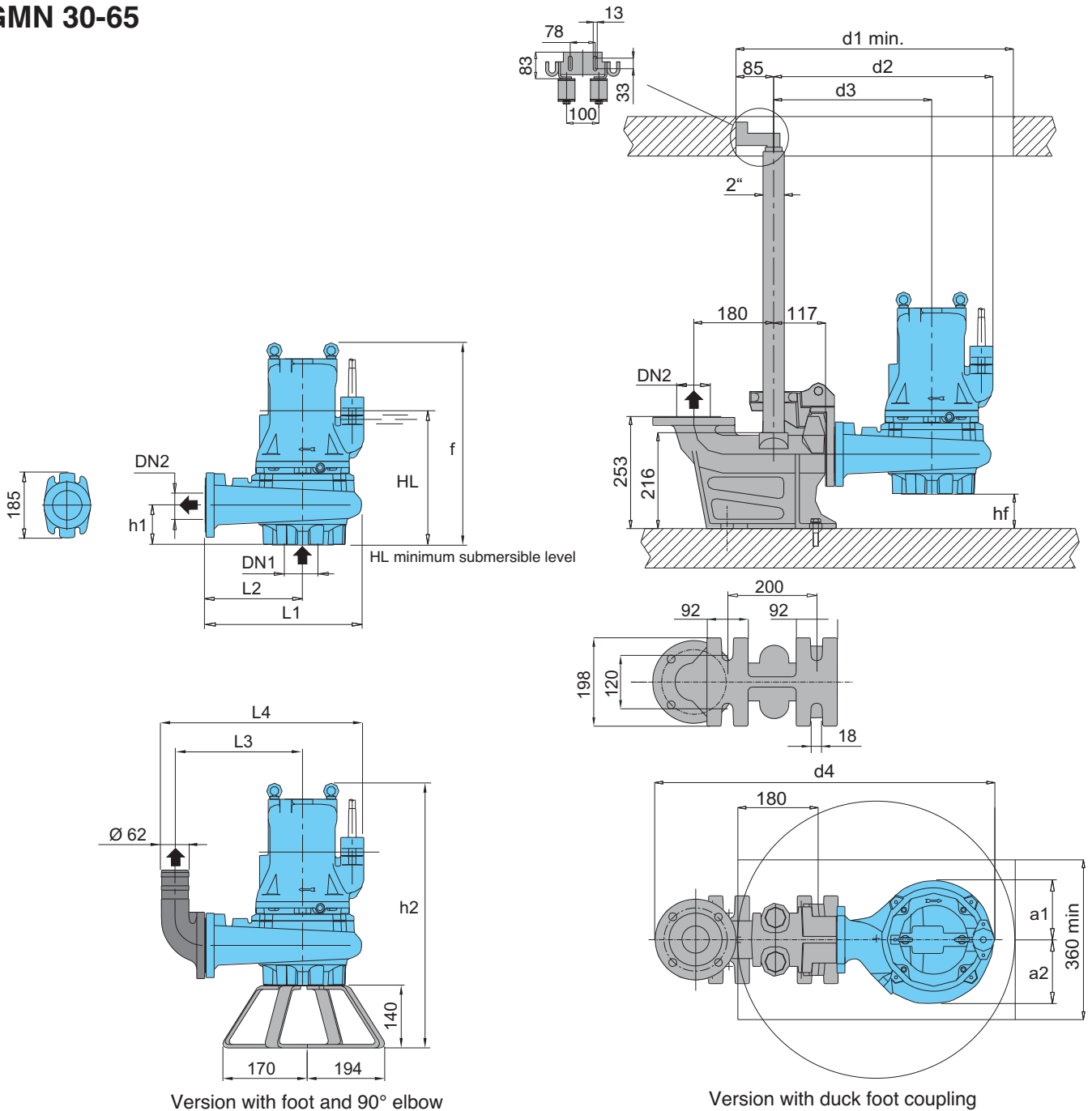

Version with foot and 90° elbow

Version with duck foot coupling

TYPE	EN 1092-2 PN 10		Dimensions mm														Weight kg	
	DN1	DN2	f	HL	hf	h1	h2	a1	a2	d1	d2	d3	d4	L1	L2	L3		L4
GMN 30-65B	80	65	456	300	78	90	596	133	145	625	495	357	767	358	220	289	458	61
GMN 30-65A																		

### Dimensions and weights

#### GMN 30-80

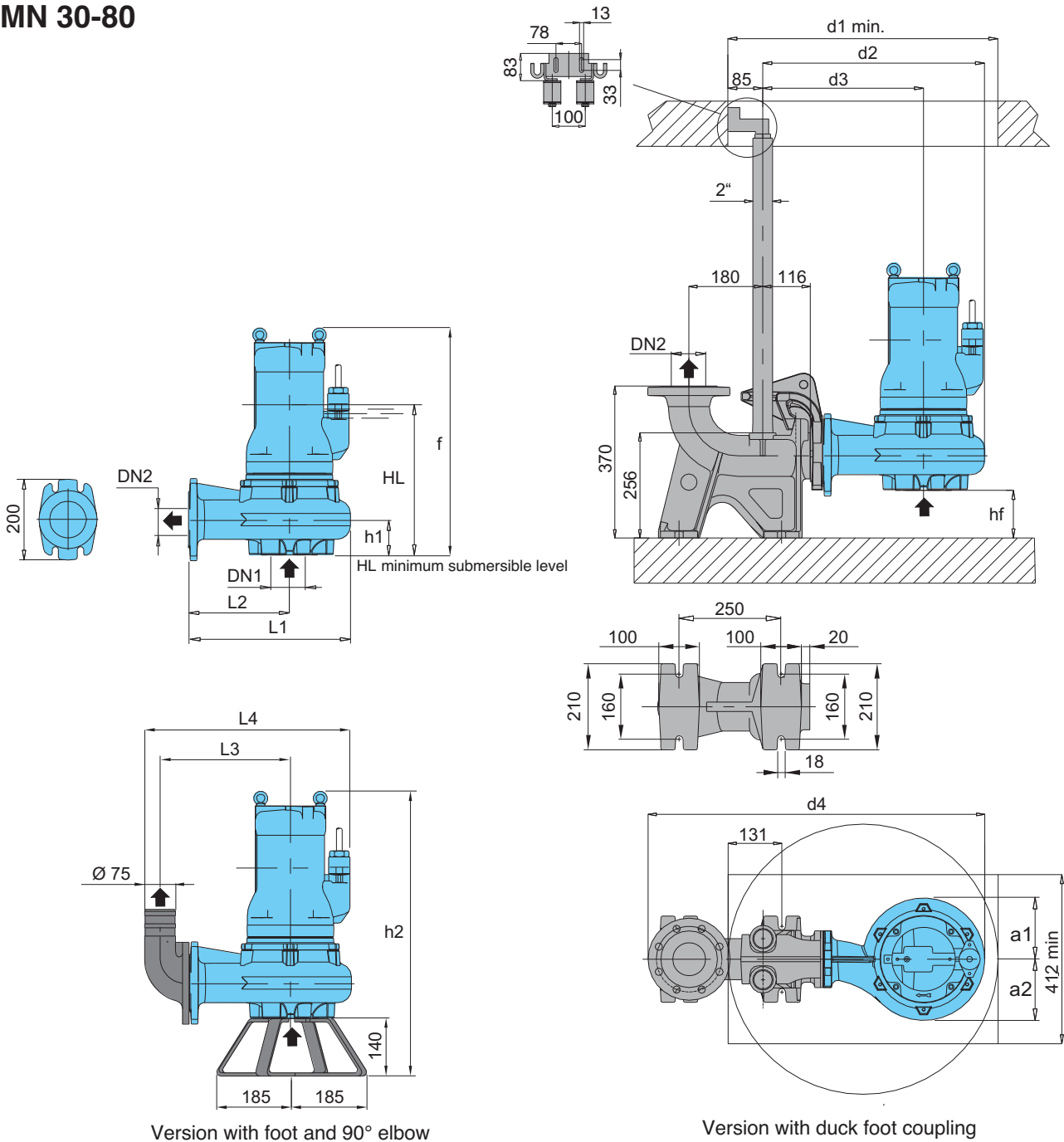

TYPE	EN 1092-2 PN 10		Dimensions mm														Weight kg	
	DN1	DN2	f	HL	hf	h1	h2	a1	a2	d1	d2	d3	d4	L1	L2	L3		L4
GMN 30-80B	80	80	515	330	110	90	655	133	145	700	511	366	791	365	220	293	475	77
GMN 30-80A	80	80	767	438	132	68	917	165	165	700	571	386	851	405	220	292	515	150

### Dimensions and weights

**GMN 40-100**  
**GMN 50-100**  
**GMN4 80-100**  
**GMN6 80-100**

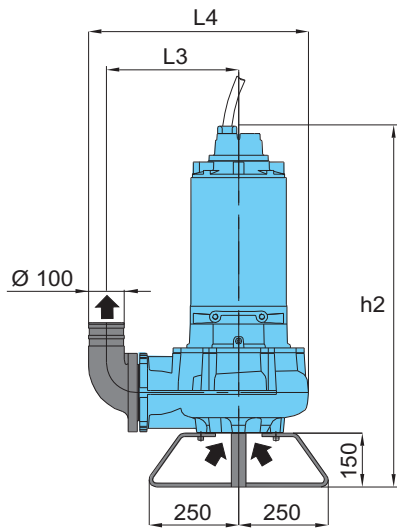
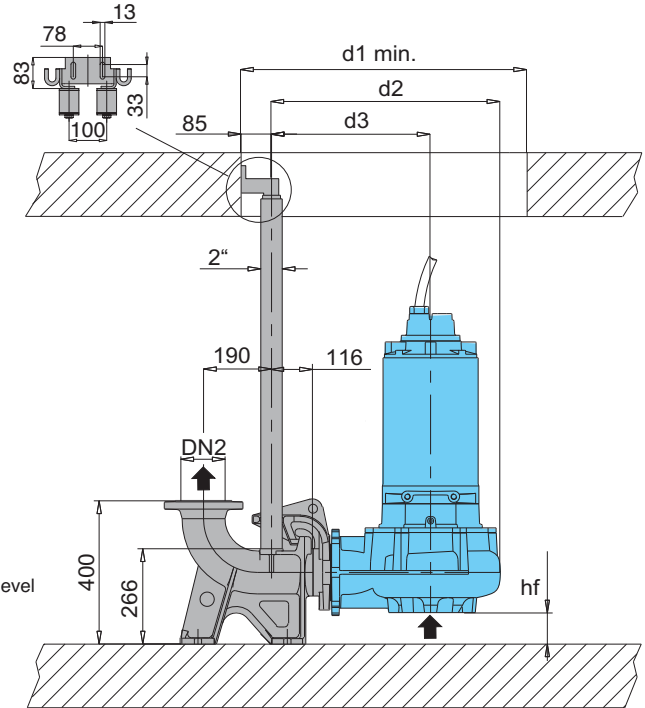
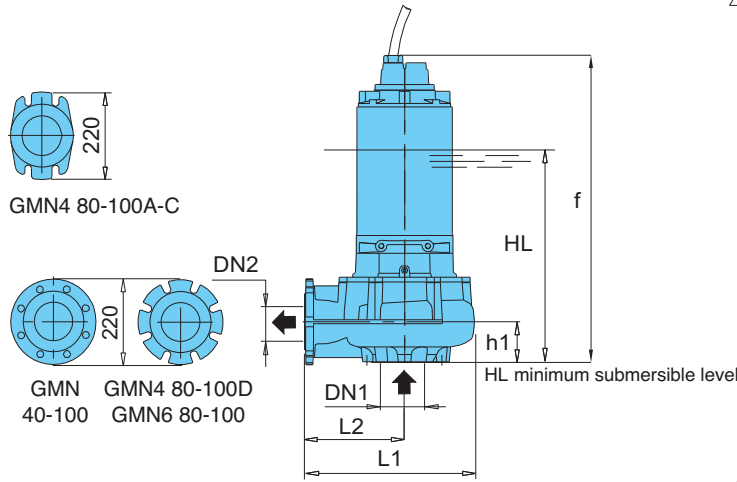

Version with foot and 90° elbow

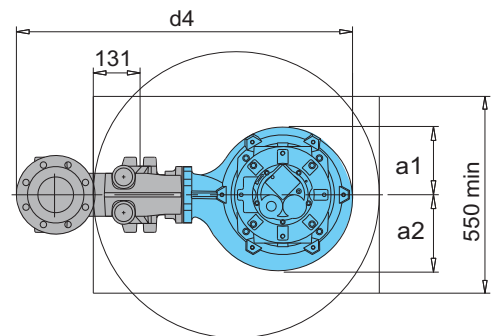
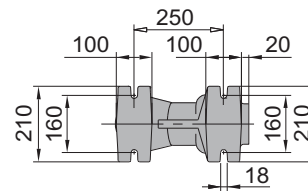

Version with duck foot coupling

TYPE	EN 1092-2 PN 10		Dimensions mm														Weight kg	
	DN1	DN2	f	HL	hf	h1	h2	a1	a2	d1	d2	d3	d4	L1	L2	L3		L4
GMN 40-100D	125	100	794	480	127	73	944	168	184	750	628	441	928	462	275	365	602	200
GMN 40-100C			794	480	127	73	944	168	184	750	628	441	928	462	275	365	602	200
GMN 40-100B			794	480	127	73	944	168	184	750	628	441	928	462	275	365	602	200
GMN 40-100S	125	100	1269	570	127	73	1419	193	193	800	628	441	928	462	280	365	602	340
GMN4 80-100D	125	100	597	424	62	138	747	180	231	850	673	466	973	507	300	390	647	110
GMN4 80-100C	125	100	852	526	54	147	1002	189	212	800	640	445	940	474	279	369	614	160
GMN4 80-100A	125	100	920	570	54	147	1040	189	212	800	640	445	940	474	279	369	614	200
GMN6 80-100B	125	100	531	372	62	138	681	180	231	850	673	466	973	507	300	390	647	86
GMN6 80-100A			597	424	62	138	747	180	231	850	673	466	973	507	300	390	647	111

### Dimensions and weights

GMN6 80-150  
 GMN6 100-150  
 GMN4 80-150  
 GMN4 100-150

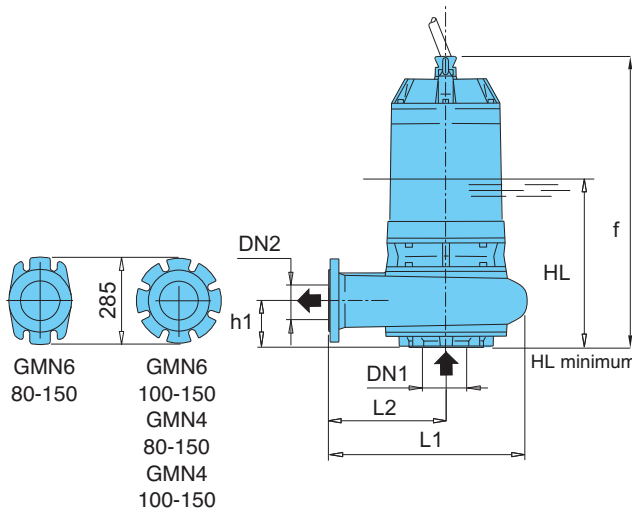

GMN6 80-150  
 GMN6 100-150  
 GMN4 80-150  
 GMN4 100-150

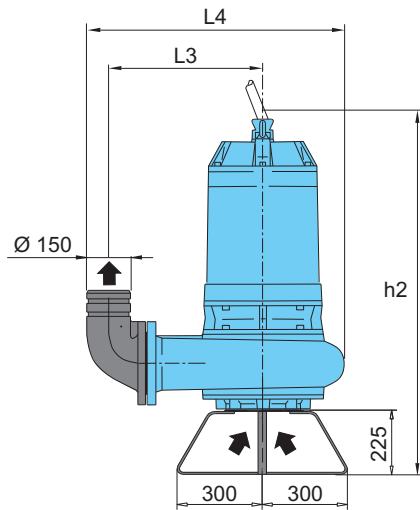
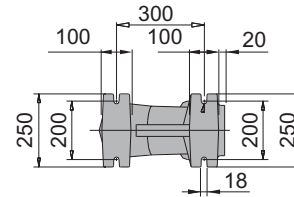
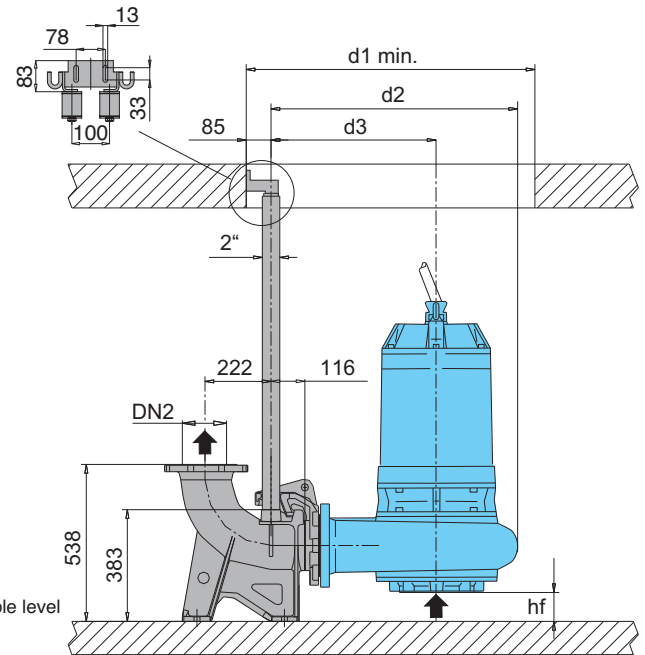

Version with foot and 90° elbow

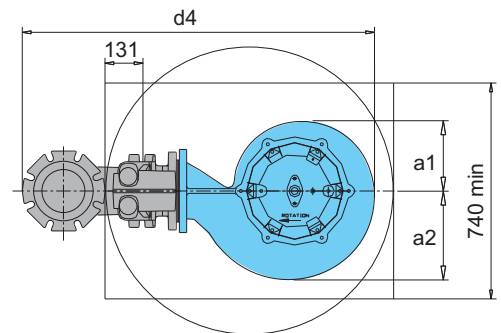

Version with duck foot coupling

TYPE	EN 1092-2 PN 10		Dimensions mm														Weight kg	
	DN1	DN2	f	HL	hf	h1	h2	a1	a2	d1	d2	d3	d4	L1	L2	L3		L4
GMN6 80-150B	150	150	820	540	113	147	1042	191	223	850	673	467	1038	507	301	431	712	186
GMN6 80-150A			933	580														
GMN6 100-150B/A	150	150	1409	737	80	180	1630	239	304	990	840	566	1208	673	400	530	878	450
GMN6 100-150A/A			1409	737														
GMN4 80-150C/A	150	150	1409	737	80	180	1630	239	304	990	840	566	1208	673	400	530	878	450
GMN4 80-150B/A	150	150	1439	742	80	180	1660	239	304	990	840	566	1208	673	400	530	878	515
GMN4 100-150G	150	150	1409	737	80	180	1630	239	304	990	840	566	1208	673	400	530	878	450
GMN4 100-150F																		
GMN4 100-150E/A																		
GMN4 100-150D/A																		
GMN4 100-150S/A	150	150	1439	742	80	180	1660	239	304	990	840	566	1208	673	400	530	878	515

### Dimensions and weights

GMN4 100-200  
GMN6 100-200  
GMN8 100-200

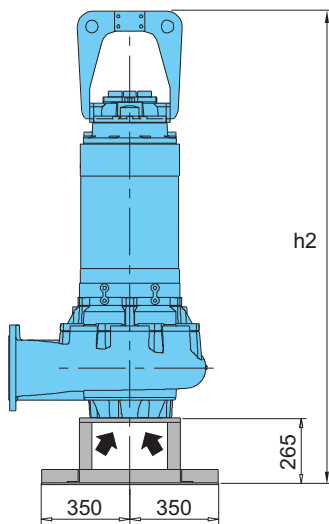
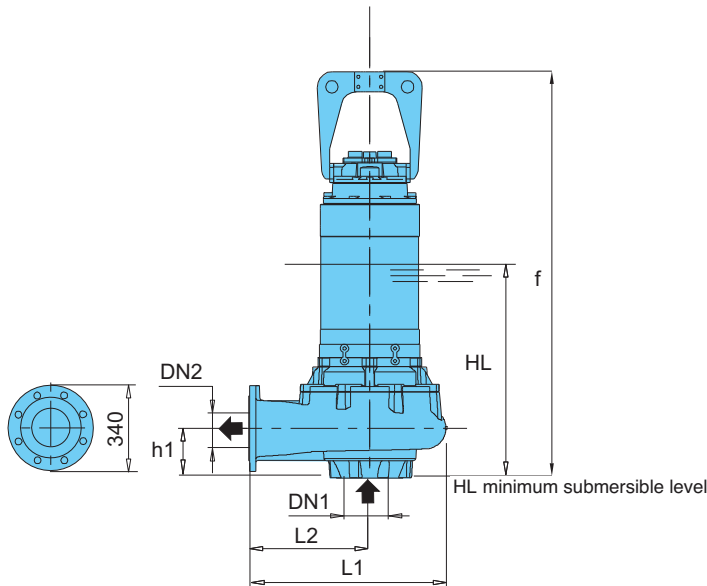

Version with foot

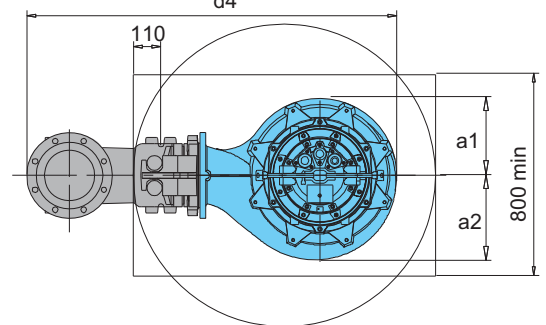
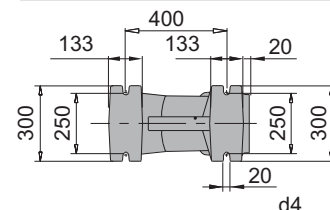
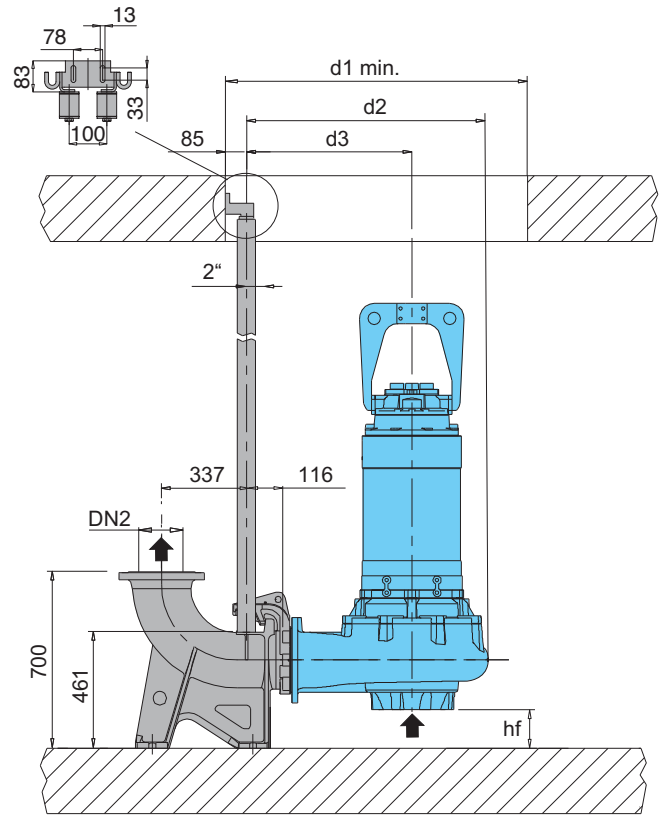

Version with duck foot coupling

TYPE	EN 1092-2 PN 10		Dimensions mm														Weight kg	
	DN1	DN2	f	HL	hf	h1	h2	a1	a2	d1	d2	d3	d4	L1	L2	L3		L4
GMN4 100-200C	200	200	1613	780	153	198	1878	306	335	1200	962	656	1469	786	480	-	-	665
GMN4 100-200B																		
GMN4 100-200A																		
GMN6 100-200F/A	200	200	1392	665	153	180	1655	269	336	1200	958	656	1314	782	480	-	-	460
GMN6 100-200E/A																		
GMN6 100-200D/A																		
GMN8 100-200B/B	200	200	1392	665	153	180	1655	269	335	1200	958	656	1314	782	480	-	-	435
GMN8 100-200A																		



### Dimensions and weights

**GMN4 100-250**  
**GMN6 100-250**  
**GMN8 100-250**

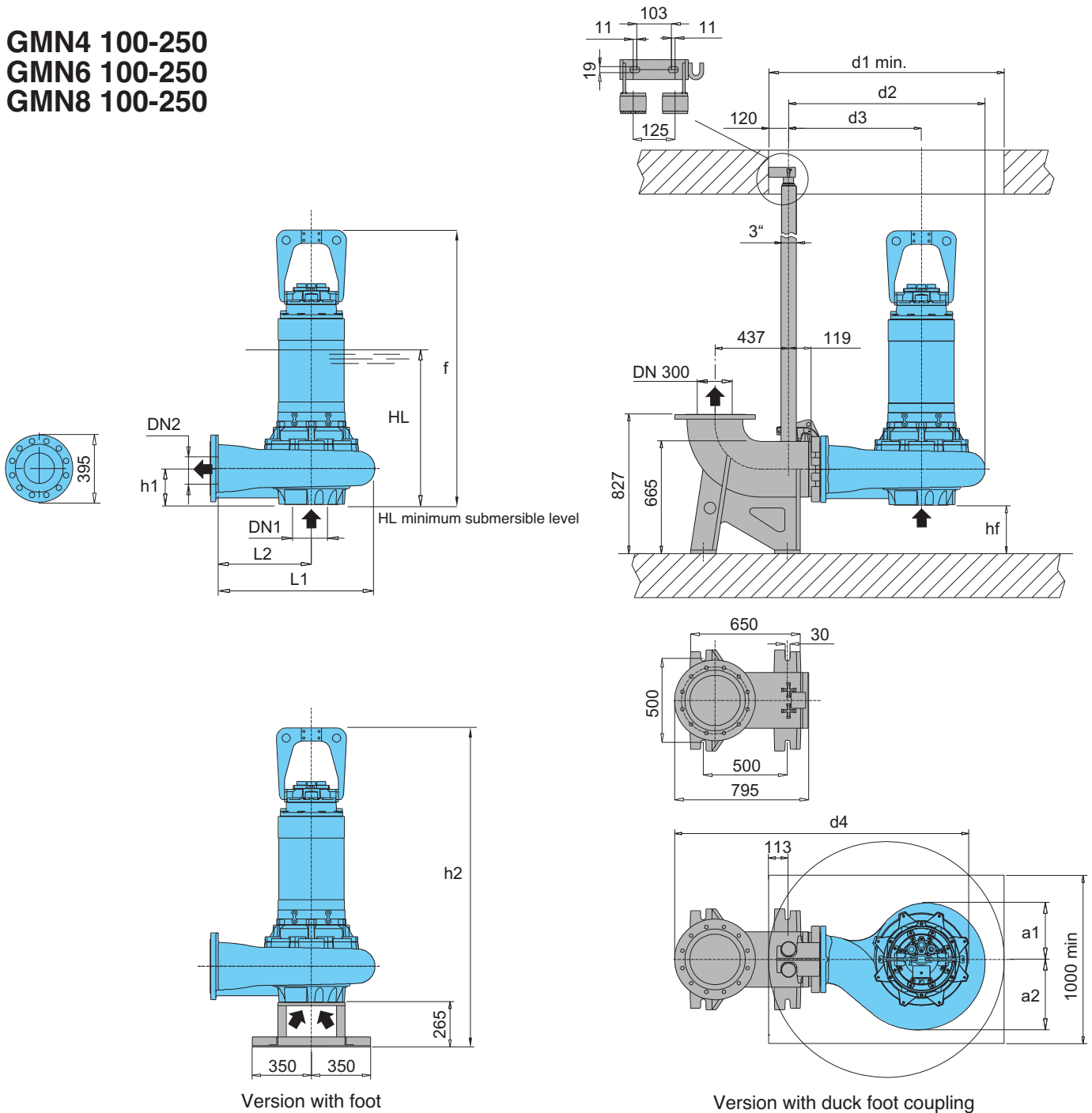

TYPE	EN 1092-2 PN 10		Dimensions mm														Weight kg	
	DN1	DN2	f	HL	hf	h1	h2	a1	a2	d1	d2	d3	d4	L1	L2	L3		L4
GMN4 100-250D	250	250	1710	835	286	214	1975	336	419	1400	1167	789	1843	978	600	-	-	914
GMN4 100-250C																		
GMN4 100-250A																		
GMN6 100-250D	250	250	1408	735	250	180	1670	336	419	1400	1203	789	1843	1014	600	-	-	510
GMN6 100-250C			1437															1702
GMN6 100-250B	250	250	1629	800	286	214	1894	336	419	1400	1167	789	1843	978	600	-	-	730
GMN6 100-250A																		
GMN8 100-250B/A	250	250	1408	735	250	180	1670	336	419	1400	1203	789	1843	1014	600	-	-	520
GMN8 100-250A/B																		1437

### Dimensions and weights

#### GMN6 140-300

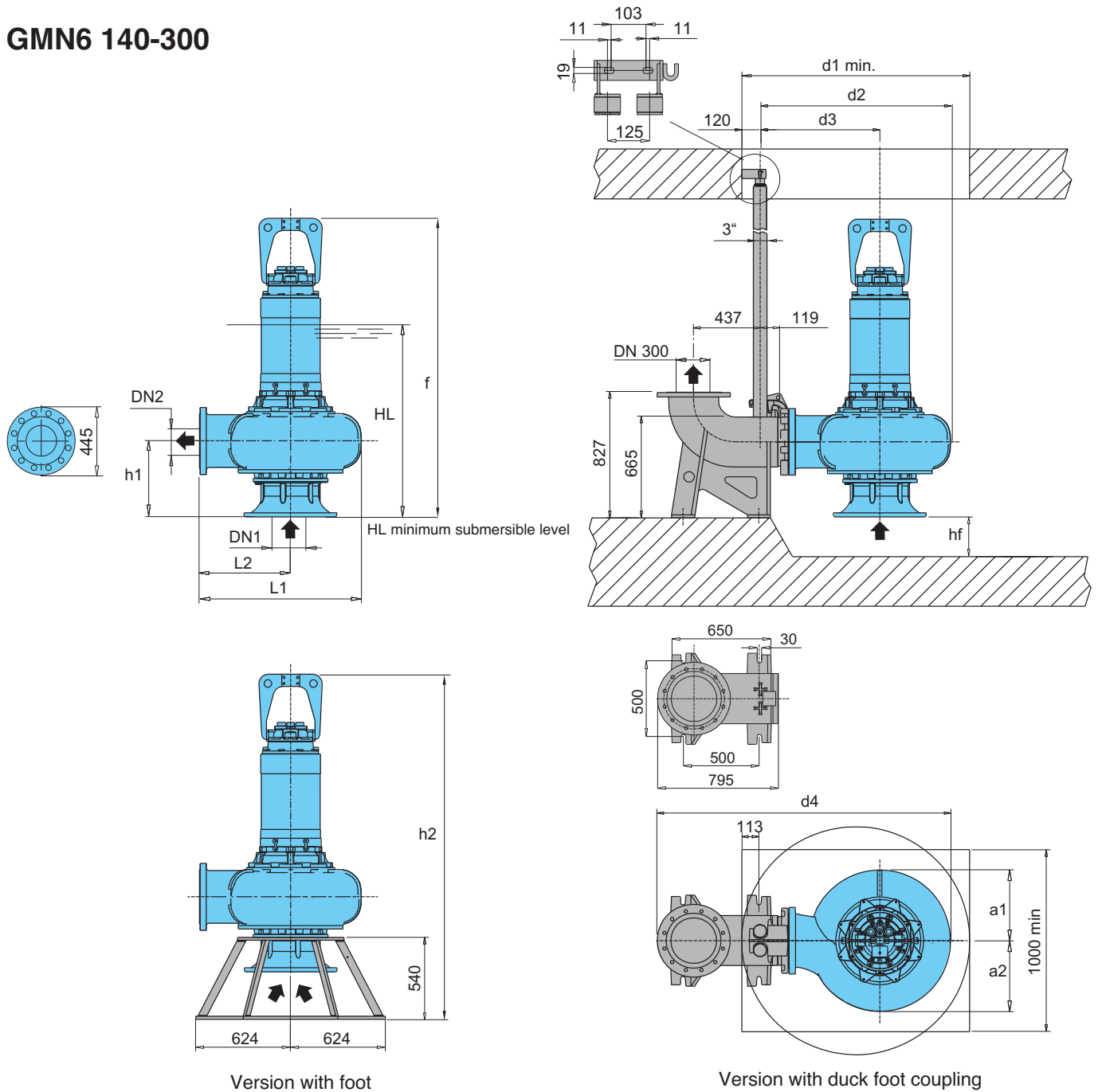

TYPE	EN 1092-2 PN 10		Dimensions mm														Weight kg	
	DN1	DN2	f	HL	hf	h1	h2	a1	a2	d1	d2	d3	d4	L1	L2	L3		L4
GMN6 140-300D																		
GMN6 140-300C	350	300	1959	1127	260	494	2271	465	465	1500	1254	789	1930	1065	600	-	-	1042
GMN6 140-300B	350	300	2040	1164	260	494	2352	465	465	1500	1254	789	1930	1065	600	-	-	1230
GMN6 140-300A	350	300	1959	1127	260	494	2271	465	465	1500	1254	789	1930	1065	600	-	-	1024



### Construction

Submersible pumps in **AISI 316** stainless steel.  
**I-GMV** with free-flow (vortex) impeller  
**I-GMC** with single-channel impeller  
**I-GMN** with channels impeller  
 Twin mechanical seal with oil chamber (lip-seal motor side up to 2,4 kW 2 poles).  
 Delivery connection DN 50-65-80-100-150

### Applications

Suitable to pump aggressive and corrosive liquids, particularly to drain waste water in industrial and chemical process plants.  
 Solid passage from 30 to 100 mm

### Operating conditions

Liquid temperature up to 40 °C.  
 Maximum immersion depth: 20 m (with suitable cable length).  
 Continuous duty (with pump immersed at minimum level).

### Main materials

- Pump casing: stainless steel AISI 316
- Motor casing: stainless steel AISI 316
- Motor cover: stainless steel AISI 316
- Impeller: stainless steel AISI 316
- Shaft: stainless steel AISI 316L
- Screws: stainless steel AISI 316
- Mechanical seal motor side: graphite/ceramic/FPM (lip-seal made of nitrile up to 2,4 kW 2 poles).
- Mechanical seal pump side: silicon carbide/silicon carbide/FPM

### Motor

- 2 or 4 poles induction, 50Hz
- Three-phase version: 400V ± 10%, up to 3,2 kW  
400/690V ± 10%, over 3,2 kW
- Insulation class: H
- Protection degree: IP 68
- N° of starting x hour: max 15 with regular intervals
- Cable: H07RN-F, length 10 m
- Other models: contact our sale office

### Coverage chart

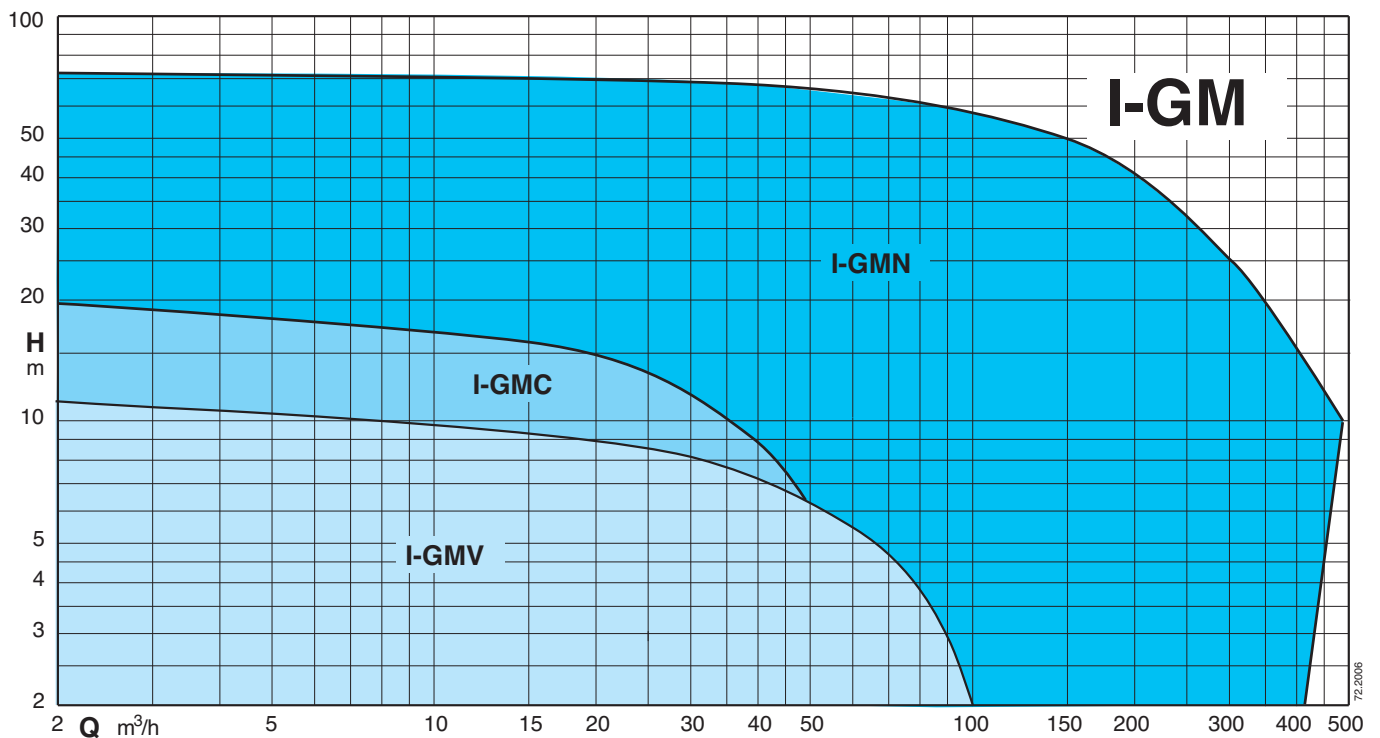

### Technical data

TYPE	P <sub>2</sub> kW	I <sub>N</sub> A	Power Supply	r.p.m.	Starting	DN mm	Free passage Ø mm	Thermal protector	Humidity probe	 ATEX Eex
I-GMV 50-50C	1,4	3,5	3~ 400V	2850	D.O.L.	50	50	NO	NO	✓
I-GMV 50-50B/A	1,4	3,5	3~ 400V	2850	D.O.L.	50	50	NO	NO	✓
I-GMV 50-50A/A	2,4	5	3~ 400V	2850	D.O.L.	50	50	NO	NO	✓
I-GMV4 50-65C	1	3	3~ 400V	1450	D.O.L.	65	50	NO	NO	✓
I-GMV4 50-65B	1	3	3~ 400V	1450	D.O.L.	65	50	NO	NO	✓
I-GMV4 50-65A	1,3	3,5	3~ 400V	1450	D.O.L.	65	50	NO	NO	✓
I-GMV4 50-80B	2,3	5	3~ 400V	1450	D.O.L.	80	50	NO	NO	✓
I-GMV4 50-80A	2,8	6,5	3~ 400V	1450	D.O.L.	80	50	NO	NO	✓
I-GMC 40-65B	2,4	5	3~ 400V	2850	D.O.L.	65	40	NO	NO	✓
I-GMC 40-65A	2,9	6	3~ 400V	2850	D.O.L.	65	40	NO	NO	✓
I-GMN 30-65B	3,2	6,5	3~ 400V	2850	D.O.L.	65	30	NO	NO	✓
I-GMN 30-65A	3,2	6,5	3~ 400V	2850	D.O.L.	65	30	NO	NO	✓
I-GMN 30-80B	5,7	12,5	3~ 400/690V	2850	Y/Δ	80	30	●	●	✓
I-GMN 30-80A	5,7	12,5	3~ 400/690V	2850	Y/Δ	80	30	●	●	✓
I-GMN 30-80S	8,2	15,5	3~ 400/690V	2850	Y/Δ	80	30	●	●	✓
I-GMN 40-100D	13,8	29,5	3~ 400/690V	2850	Y/Δ	100	40	●	●	✓
I-GMN 40-100C	13,8	29,5	3~ 400/690V	2850	Y/Δ	100	40	●	●	✓
I-GMN 40-100B	18,2	34	3~ 400/690V	2850	Y/Δ	100	40	●	●	✓
I-GMN 40-100S	22,4	40,1	3~ 400/690V	2850	Y/Δ	100	40	●	●	✓
I-GMN 50-100C	48,2	86,5	3~ 400/690V	2850	Y/Δ	100	50	●	●	✓
I-GMN 50-100B	48,2	86,5	3~ 400/690V	2850	Y/Δ	100	50	●	●	✓
I-GMN 50-100A	48,2	86,5	3~ 400/690V	2850	Y/Δ	100	50	●	●	✓
I-GMN4 60-100B	7,1	13,5	3~ 400/690V	1450	Y/Δ	100	60	●	●	✓
I-GMN4 60-100A	7,1	13,5	3~ 400/690V	1450	Y/Δ	100	60	●	●	✓
I-GMN4 80-100B	11,6	23,2	3~ 400/690V	1450	Y/Δ	100	80	●	●	✓
I-GMN4 80-100A	11,6	23,2	3~ 400/690V	1450	Y/Δ	100	80	●	●	✓
I-GMN4 100-150B	25	48	3~ 400/690V	1450	Y/Δ	150	100	●	●	✓
I-GMN4 100-150A	35,7	65,5	3~ 400/690V	1450	Y/Δ	150	100	●	●	✓

P<sub>2</sub> Rated power output

I<sub>N</sub> Rated current

● Standard

✓ ATEX Eex Version on demand

## Characteristic curves

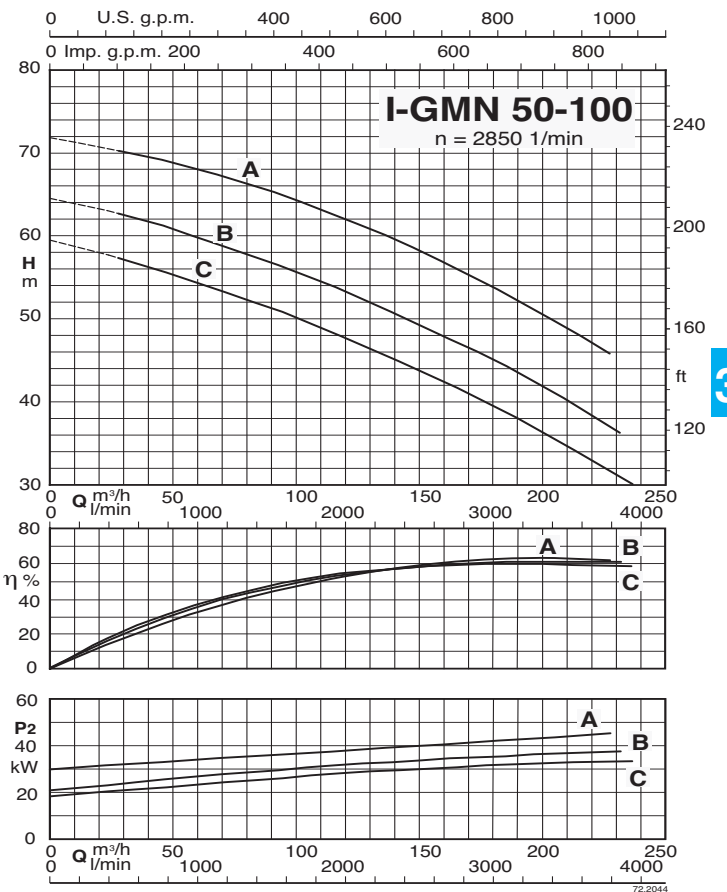
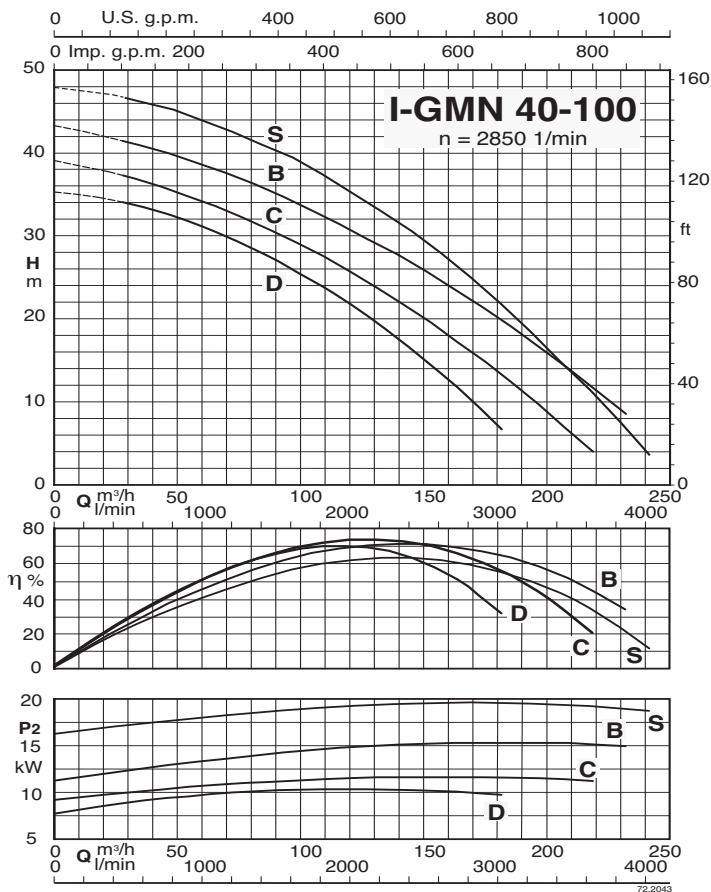
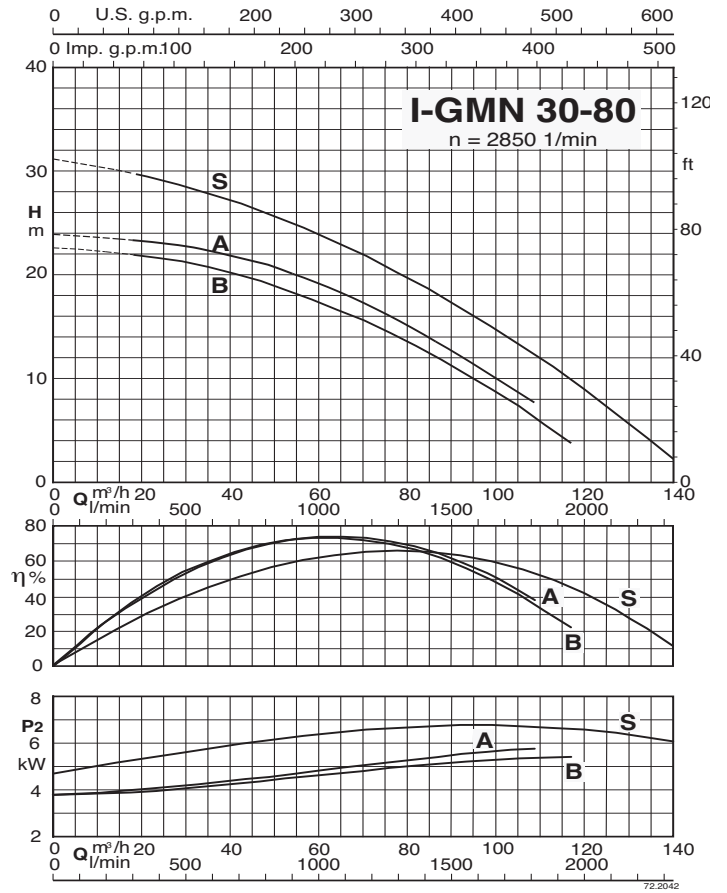
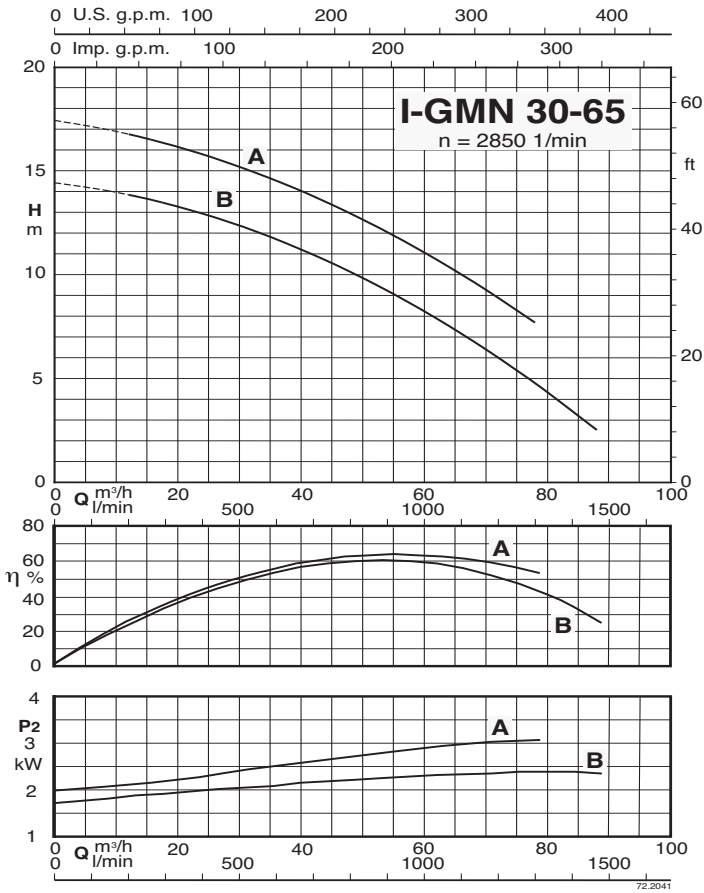

## Characteristic curves

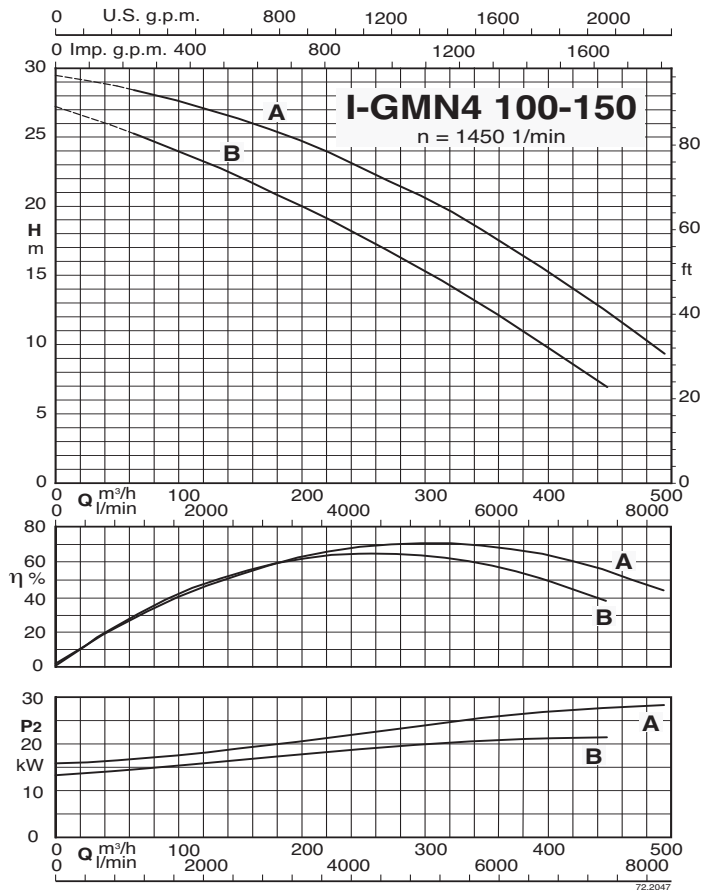
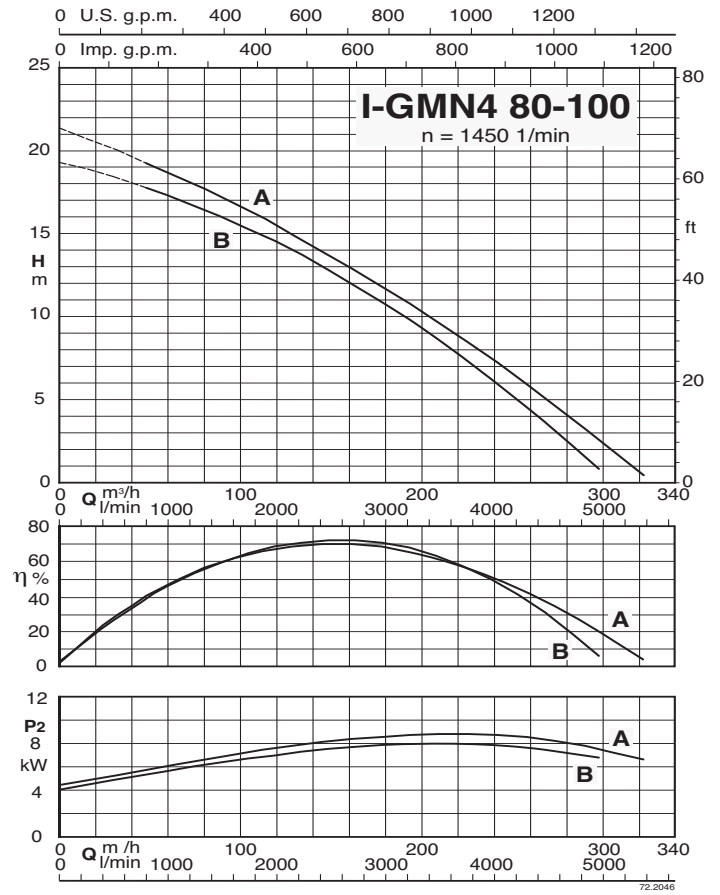
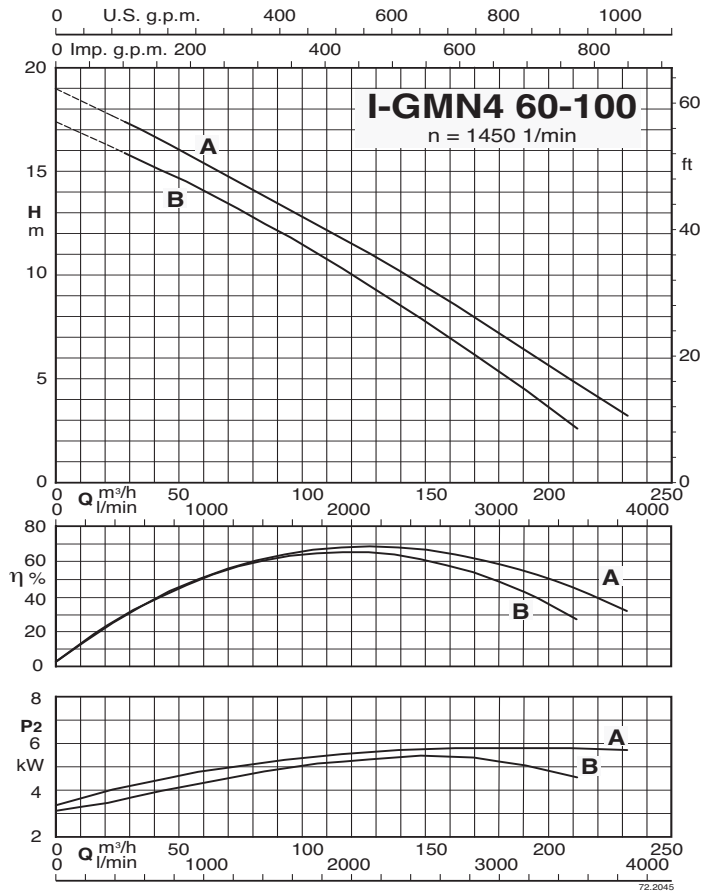

## Dimensions and weights

### I-GMN 30-65

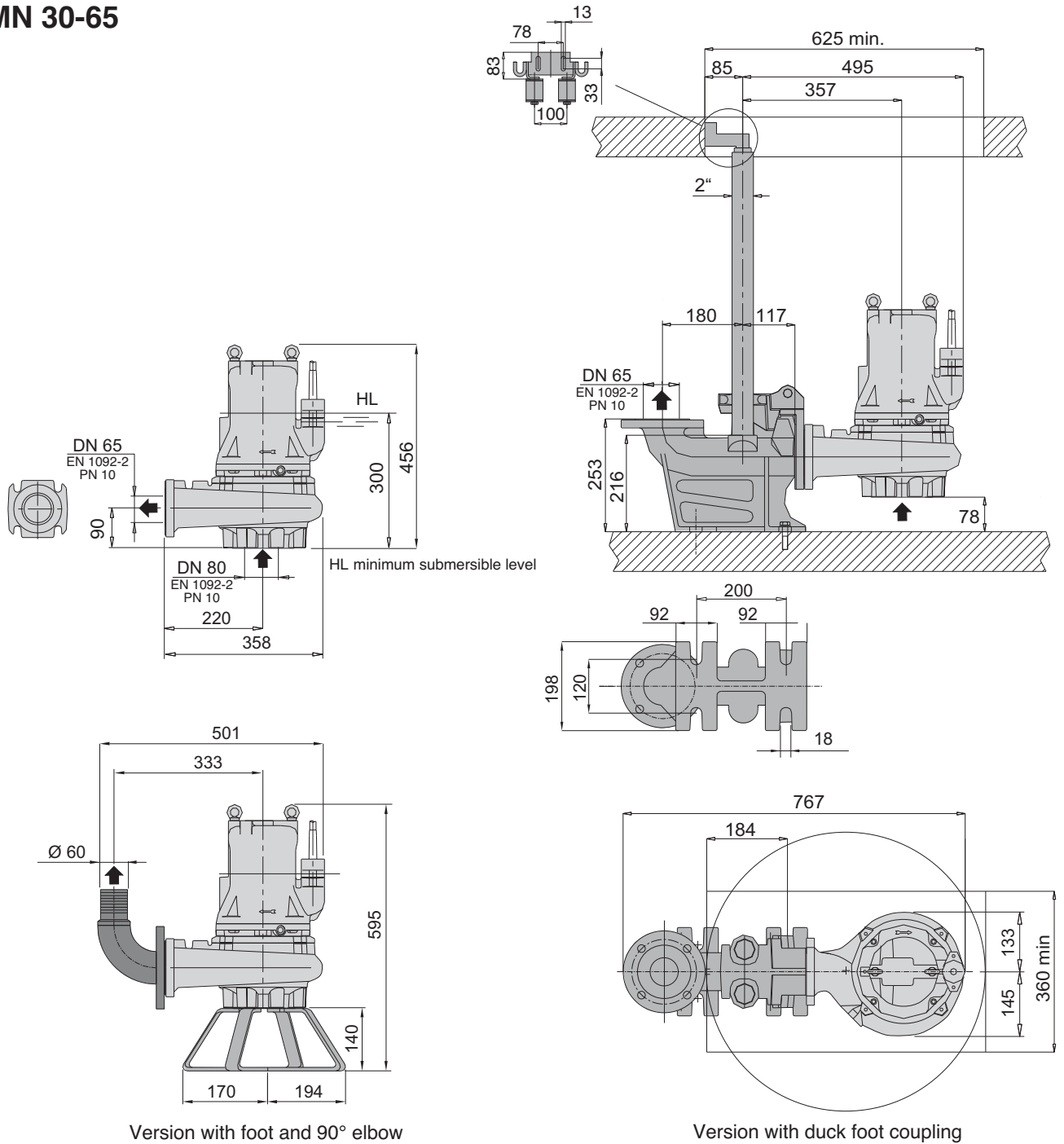

Version with foot and 90° elbow

Version with duck foot coupling

TYPE	Weight kg
I-GMN 30-65B	60
I-GMN 30-65A	



### Dimensions and weights

**I-GMV4 50-80**  
**I-GMN 30-80**

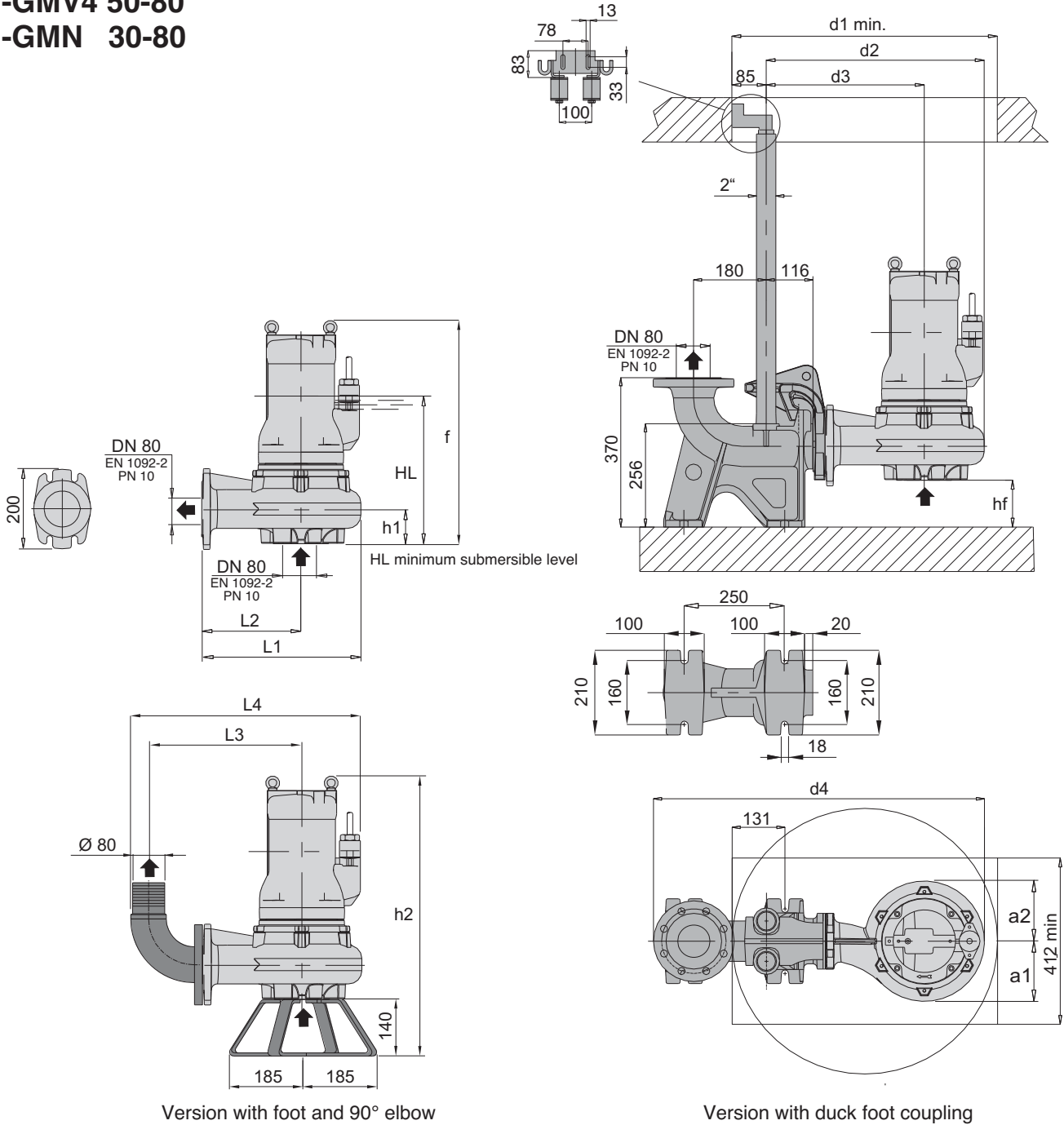

Version with foot and 90° elbow

Version with duck foot coupling

TYPE	EN 1092-2 PN 10		Dimensions mm														Weight kg	
	DN1	DN2	f	HL	hf	h1	h2	a1	a2	d1	d2	d3	d4	L1	L2	L3		L4
I-GMV4 50-80B	80	80	519	363	84	116	659	136	157	658	511	366	791	365	220	355	544	67
I-GMV4 50-80A	80	80	515	330	110	90	655	133	145	700	511	366	791	365	220	355	544	83
I-GMN 30-80B	80	80	767	438	132	68	917	165	165	700	571	386	851	405	220	362	590	170

## Dimensions and weights

- I-GMN 40-100
- I-GMN 50-100
- I-GMN4 60-100
- I-GMN4 80-100

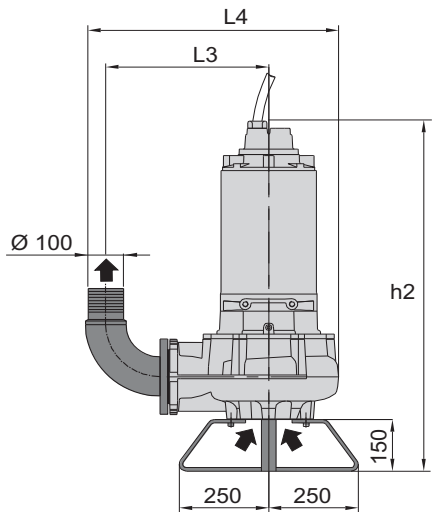
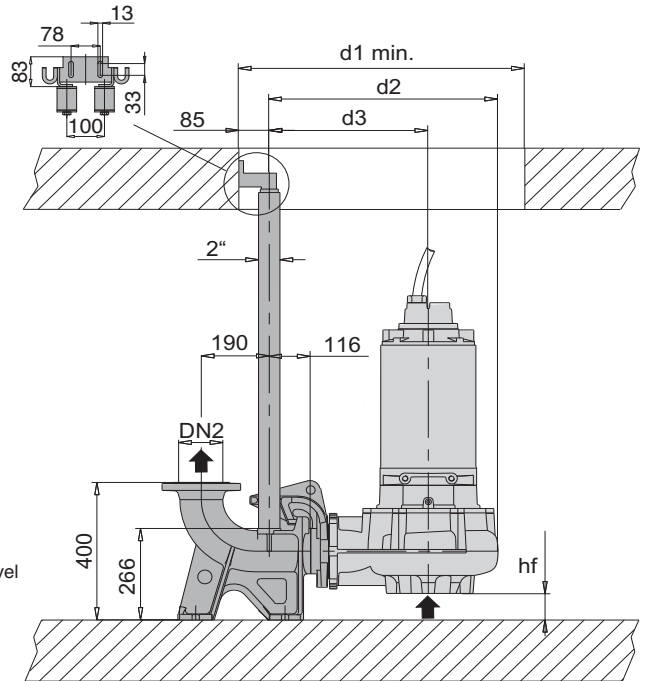
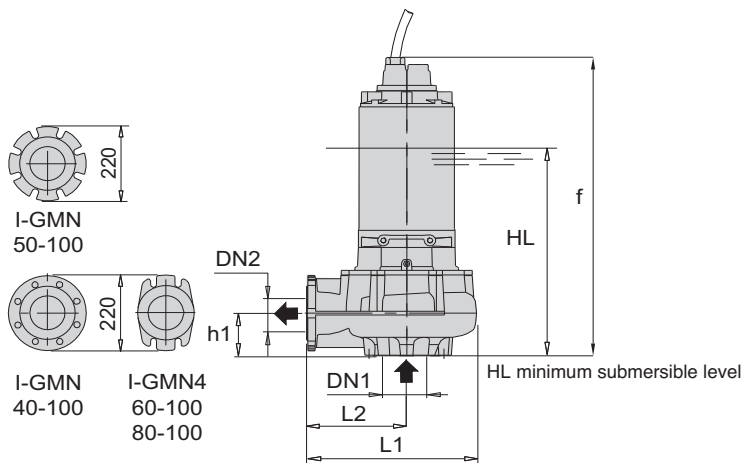

Version with foot and 90° elbow

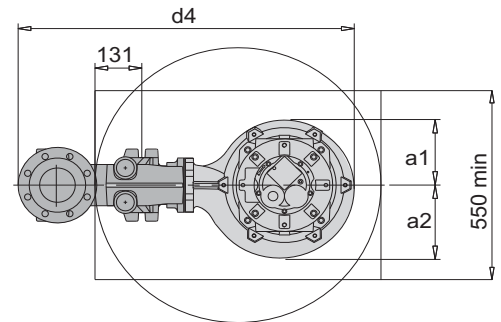
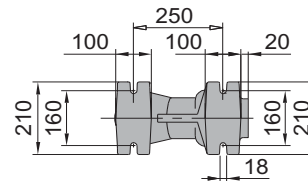

Version with duck foot coupling

TYPE	EN 1092-2 PN 10		Dimensions mm														Weight kg	
	DN1	DN2	f	HL	hf	h1	h2	a1	a2	d1	d2	d3	d4	L1	L2	L3		L4
I-GMN 40-100D	125	100	845	478	127	73	995	168	184	750	628	441	928	467	280	449	694	210
I-GMN 40-100C																		
I-GMN 40-100B																		
I-GMN 40-100S	125	100	1269	570	127	73	1419	193	193	800	628	441	928	462	280	365	602	390
I-GMN 50-100C	125	100	1033	628	62	139	1183	180	231	850	673	466	973	507	300	474	738	364
I-GMN 50-100B																		
I-GMN 50-100A																		
I-GMN4 60-100B	125	100	852	526	54	147	1002	189	212	800	640	445	940	474	279	456	706	167
I-GMN4 60-100A																		
I-GMN4 80-100B	125	100	921	570	53	147	1071	189	212	800	640	445	940	474	279	453	706	220
I-GMN4 80-100A																		

### Dimensions and weights

#### I-GMN4 100-150

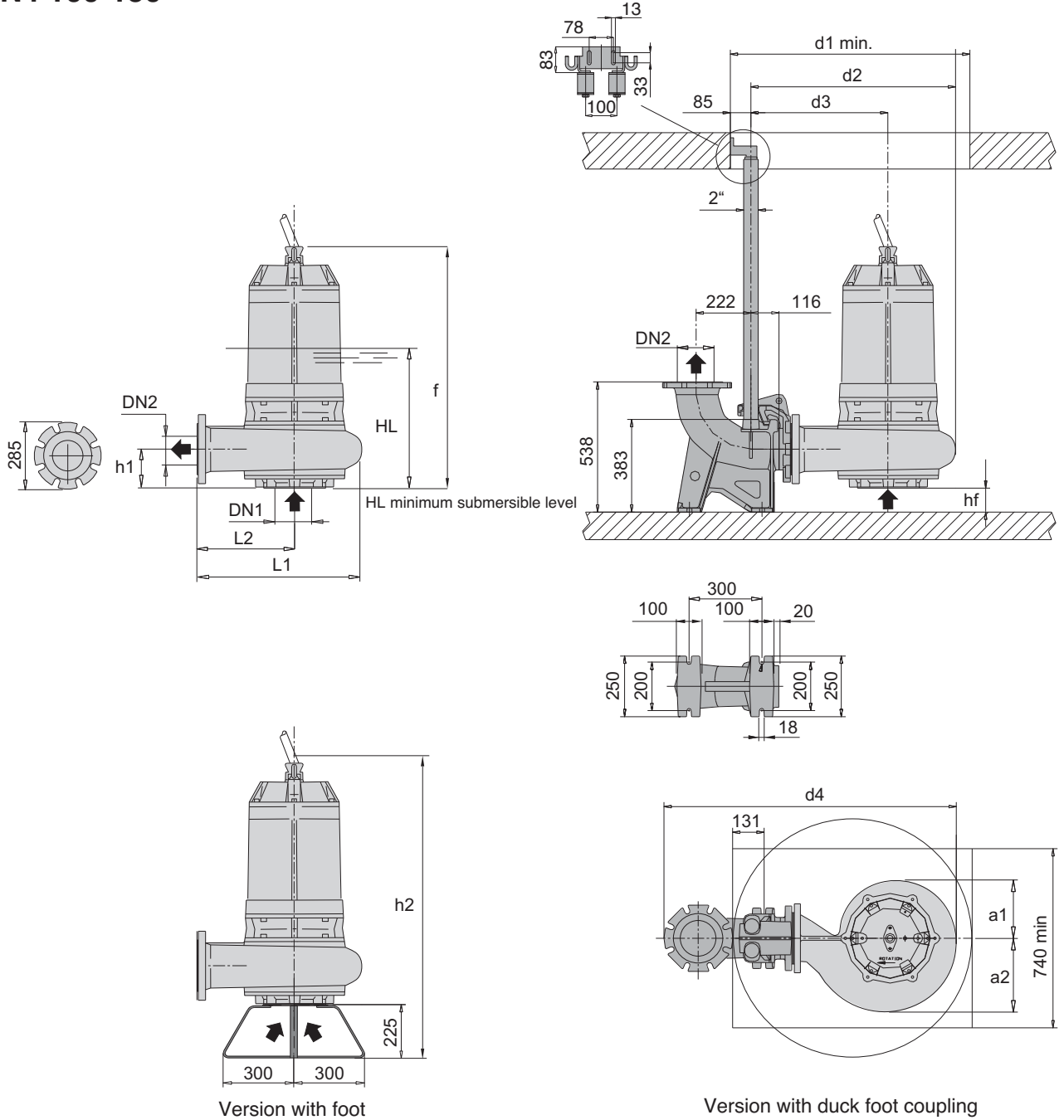

TYPE	EN 1092-2 PN 10		Dimensions mm																Weight kg
	DN1	DN2	f	HL	hf	h1	h2	a1	a2	d1	d2	d3	d4	L1	L2	L3	L4		
GMN4 100-150B	150	150	991	576	100	160	1216	235	305	990	931	566	1208	680	400	-	-	370	
GMN4 100-150A			1055	600			1293											405	



### Construction

Submersible pumps, **B 10 bronze marine** version.

**B-GMV** with free-flow (vortex) impeller

**B-GMC** with single-channel impeller

**B-GMN** with channels impeller

Twin mechanical seal with oil chamber (lip-seal motor side up to 2,4 kW 2 poles).

Delivery connection DN 50-65-80

### Applications

Suitable to pump industrial waste water in chemical, and process industries, agricultural and marine areas.

Solid passage from 30 to 50 mm

### Operating conditions

Liquid temperature up to 40 °C.

Maximum immersion depth: 20 m (with suitable cable length).

Continuous duty (with pump immersed at minimum level).

### Main materials

Pump casing, Motor casing, Motor cover: B 10 bronze marine

Impeller: stainless steel AISI 316

Motor shaft: stainless steel AISI 316L

Screws: stainless steel AISI 316

Mechanical seal motor side: graphite/ceramic/FPM (lip-seal made of nitrile up to 2,4 kW 2 poles).

Mechanical seal pump side: silicon carbide/silicon carbide/FPM

### Motor

2 or 4 poles induction, 50Hz

Three-phase version: 400V ± 10%, up to 3,2 kW

400/690V ± 10%, over 3,2 kW

Insulation class: H

Protection degree: IP 68

N° of starting x hour: max 15 with regular intervals

Cable: H07RN-F, length 10 m

Other models: contact our sale office

### Coverage chart

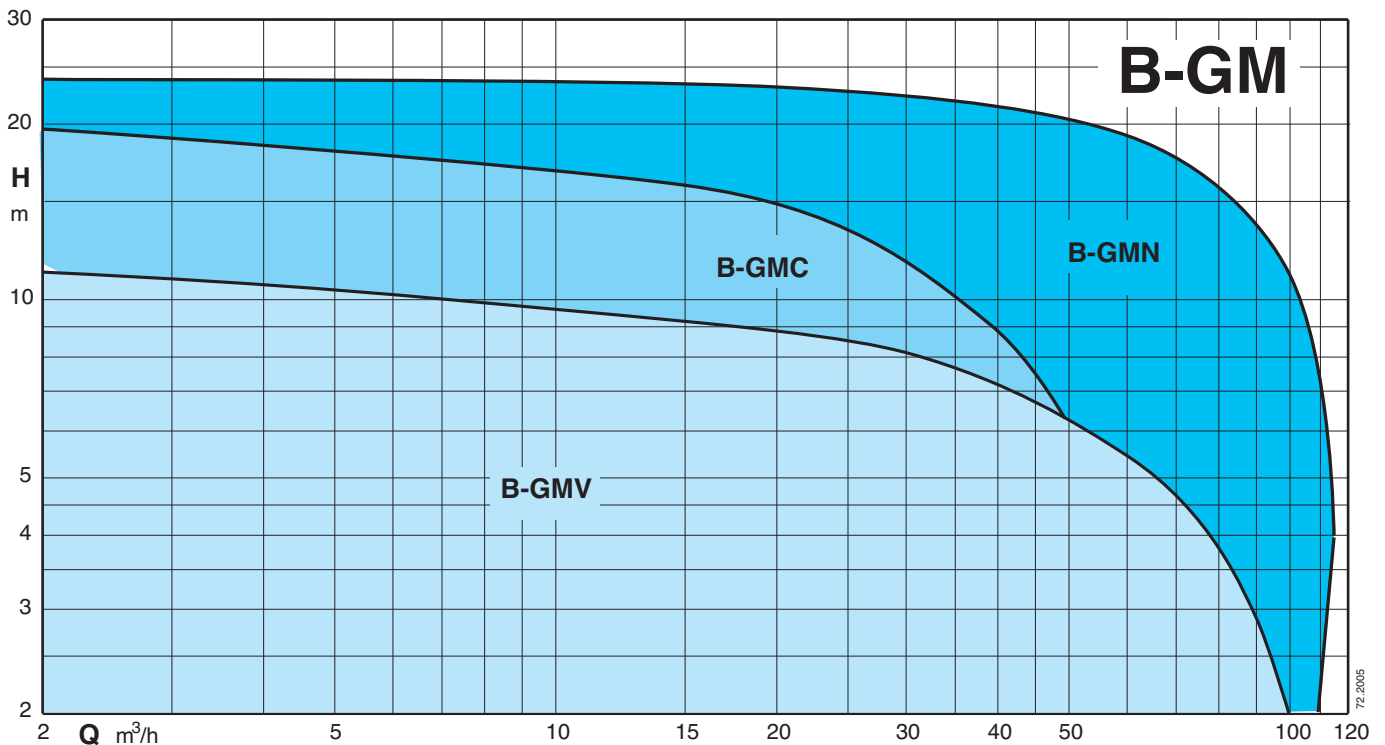

### Technical data

TYPE	P <sub>2</sub> kW	I <sub>N</sub> A	Power Supply	r.p.m.	Starting	DN mm	Free passage Ø mm	Thermal protector	Humidity probe	 ATEX Eex
B-GMV 50-50C	1,4	3,5	3~ 400V	2850	D.O.L.	50	50	NO	NO	✓
B-GMV 50-50B/A	1,4	3,5	3~ 400V	2850	D.O.L.	50	50	NO	NO	✓
B-GMV 50-50A/A	2,4	5	3~ 400V	2850	D.O.L.	50	50	NO	NO	✓
B-GMV4 50-65C	1	3	3~ 400V	1450	D.O.L.	65	50	NO	NO	✓
B-GMV4 50-65B	1	3	3~ 400V	1450	D.O.L.	65	50	NO	NO	✓
B-GMV4 50-65A	1,3	3,5	3~ 400V	1450	D.O.L.	65	50	NO	NO	✓
B-GMV4 50-80B	2,3	5	3~ 400V	1450	D.O.L.	80	50	NO	NO	✓
B-GMV4 50-80A	2,8	6,5	3~ 400V	1450	D.O.L.	80	50	NO	NO	✓
B-GMC 40-65B	2,4	5	3~ 400V	2850	D.O.L.	65	40	NO	NO	✓
B-GMC 40-65A	2,9	6	3~ 400V	2850	D.O.L.	65	40	NO	NO	✓
B-GMN 30-65B	3,2	6,5	3~ 400V	2850	D.O.L.	65	30	NO	NO	✓
B-GMN 30-65A	3,2	6,5	3~ 400V	2850	D.O.L.	65	30	NO	NO	✓
B-GMN 30-80B	5,7	12,5	3~ 400/690V	2850	Y/Δ	80	30	●	●	✓
B-GMN 30-80A	5,7	12,5	3~ 400/690V	2850	Y/Δ	80	30	●	●	✓

P<sub>2</sub> Rated power output

I<sub>N</sub> Rated current

● Standard

✓ ATEX Eex Version on demand

## Characteristic curves

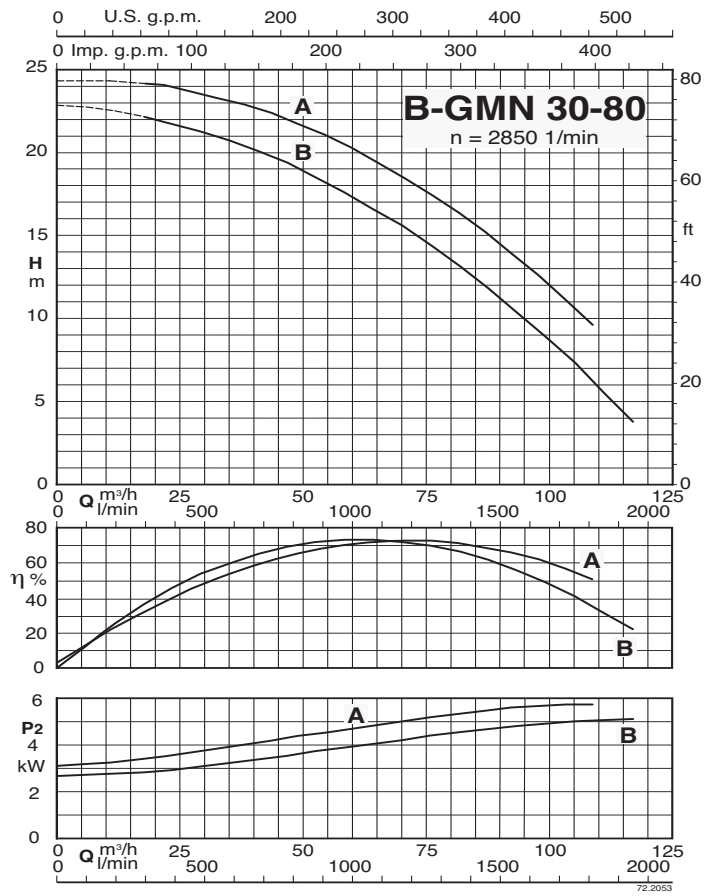
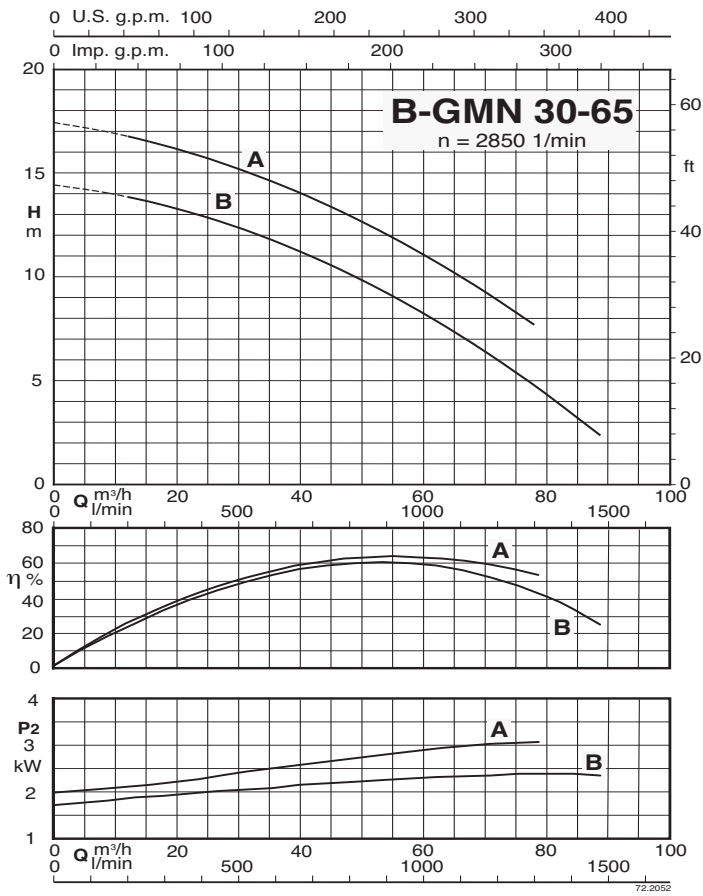

## Dimensions and weights

### B-GMN 30-65

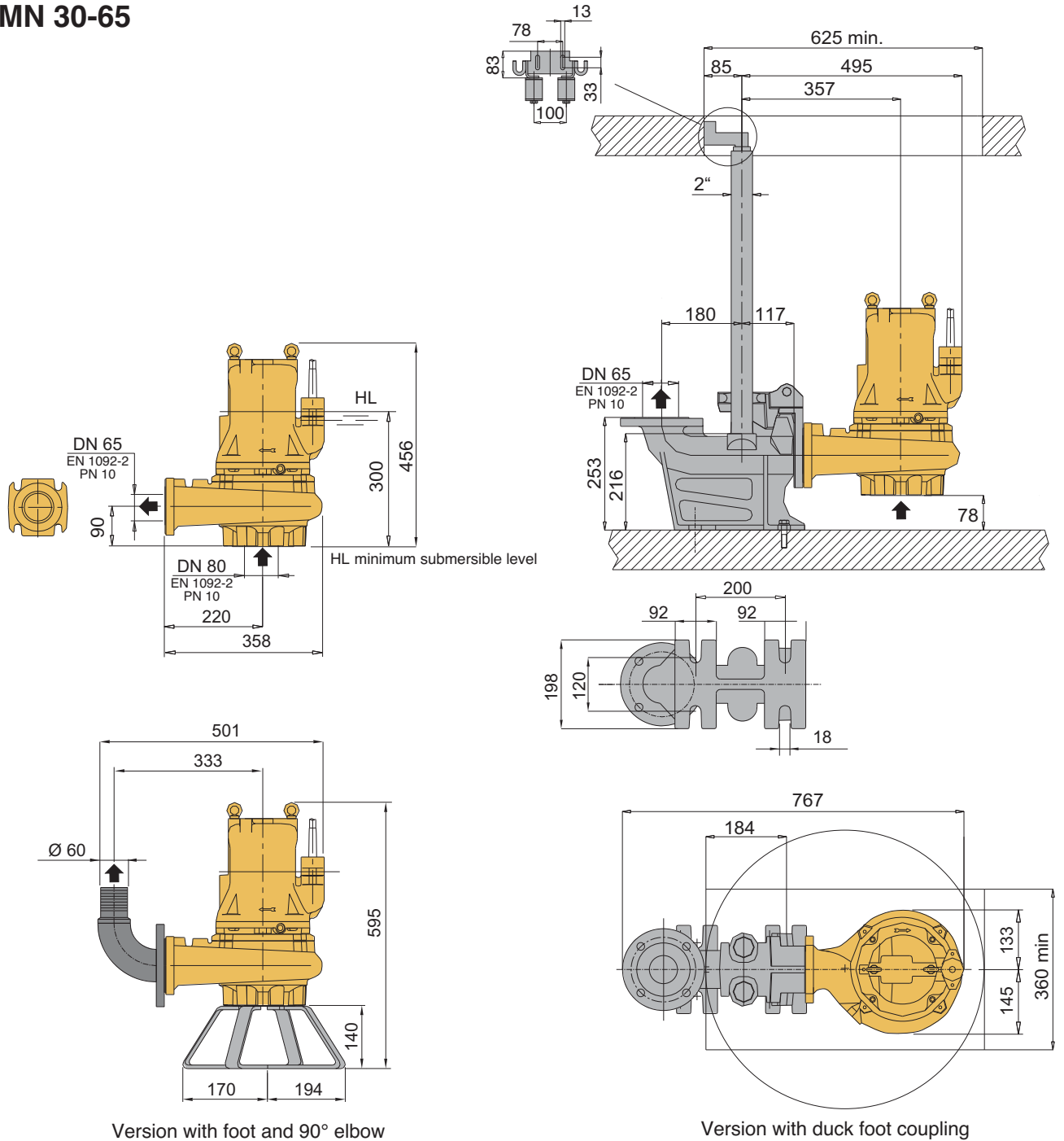

Version with foot and 90° elbow

Version with duck foot coupling

TYPE	Weight kg
B-GMN 30-65B	65
B-GMN 30-65A	



### Dimensions and weights

**B-GMV4 50-80**  
**B-GMN 30-80**

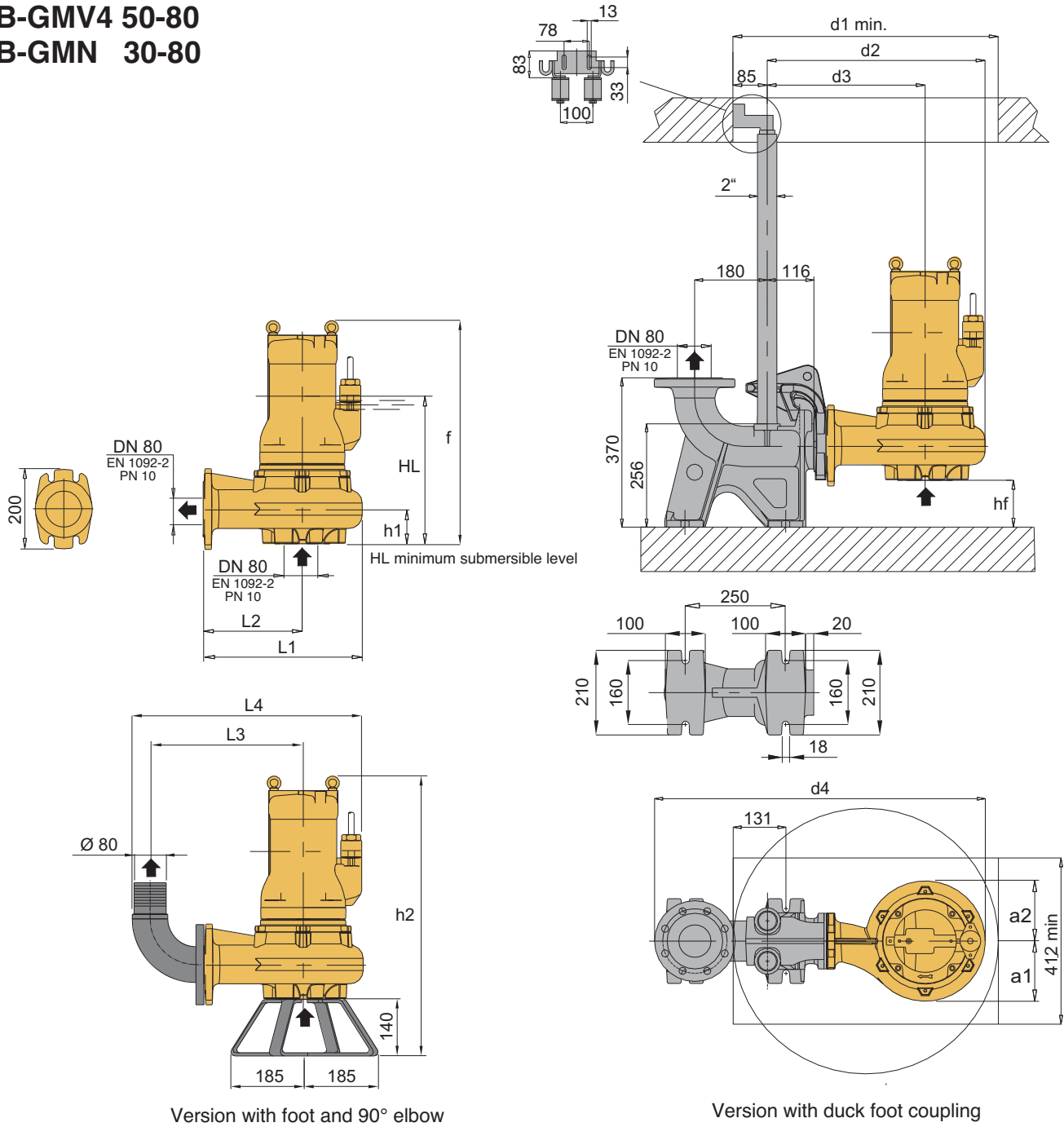

TYPE	EN 1092-2 PN 10		Dimensions mm														Weight kg	
	DN1	DN2	f	HL	hf	h1	h2	a1	a2	d1	d2	d3	d4	L1	L2	L3		L4
B-GMV4 50-80B	80	80	519	363	84	116	659	136	157	658	511	366	791	365	220	355	544	73
B-GMV4 50-80A																		
B-GMN 30-80B	80	80	515	330	110	90	655	133	145	700	511	366	791	365	220	355	544	90
B-GMN 30-80A																		