

NO. A-24005-1

# PUMP PERFORMANCE CURVES

TYPE Submersible Sewage & Wastewater Pump	MODEL 200B411 -56 T0200B411 -56	FREQUENCY 50 Hz
---	---------------------------------------	--------------------

CUSTOMER'S NAME \_\_\_\_\_

EQUIPMENT TITLE \_\_\_\_\_ NO. \_\_\_\_\_

	STANDARD SPECIFICATIONS	REQUIRED SPECIFICATIONS
DISCHARGE BORE	200 mm	mm
TOTAL HEAD	10 m	m
CAPACITY	4.5 m <sup>3</sup> /min	m <sup>3</sup> /min
MOTOR OUTPUT	11 kW	kW
PHASE × VOLTAGE	3 φ × V	φ × V
CURRENT	A	A
POLES / REVOLUTION	4 P / S. S. 1500 min <sup>-1</sup>	P / min <sup>-1</sup>
STARTING METHOD	STAR-DELTA	
INSULATION CLASS	F	

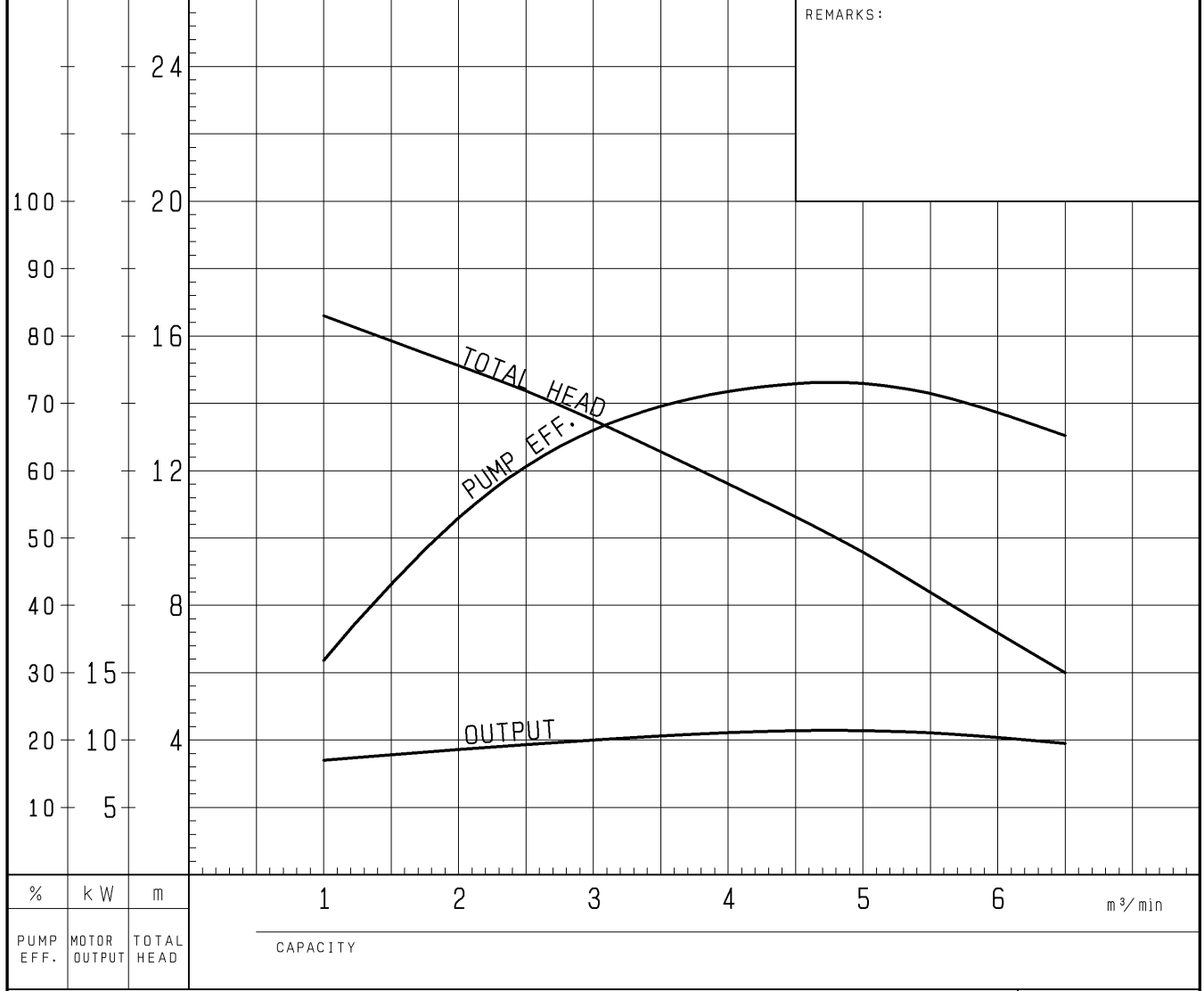

TSURUMI MFG. CO., LTD.

DIMENSION DRAWING		No.	No. A-24011-1
TYPE	Submersible Sewage & Wastewater Pump	MODEL	200B411 -56/66

Approximate Weight(\*)  
253kg  
\*excluding cable

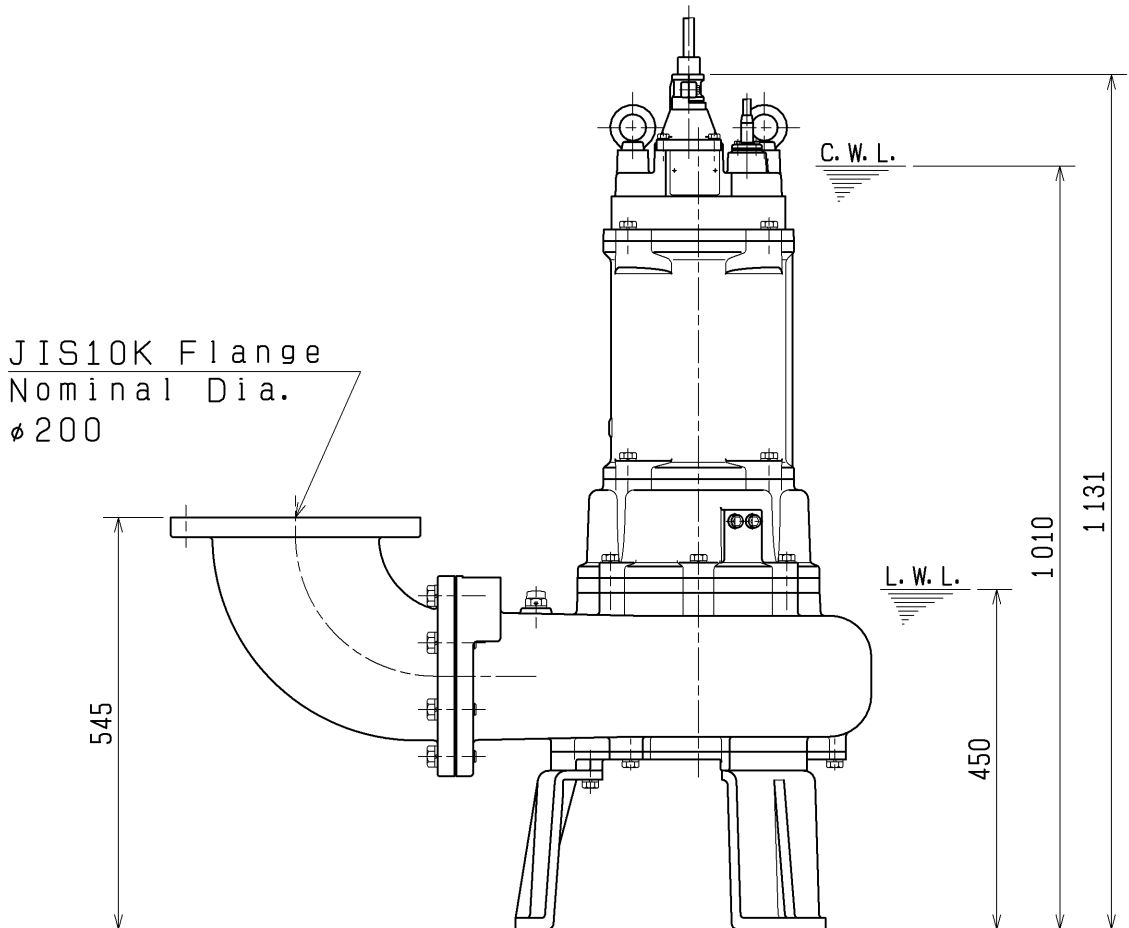
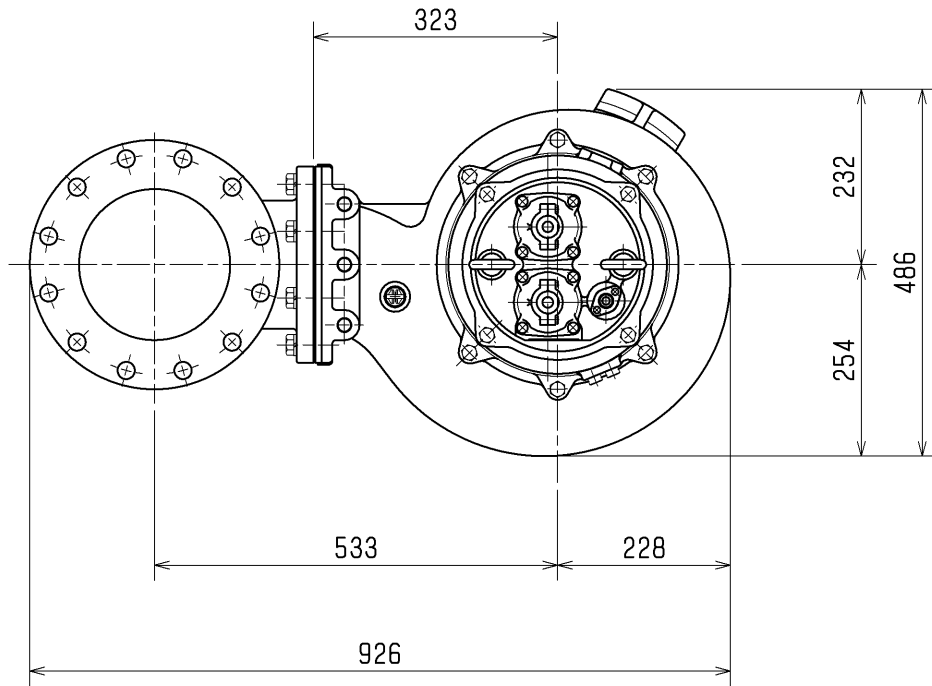

C. W. L. :Continuous running Water Level  
L. W. L. :Lowest running Water Level

<b>SECTIONAL DRAWING</b>		No.	No.	A-24014-1
TYPE	Submersible Sewage & Wastewater Pump	MODEL	200B411 -56/66	

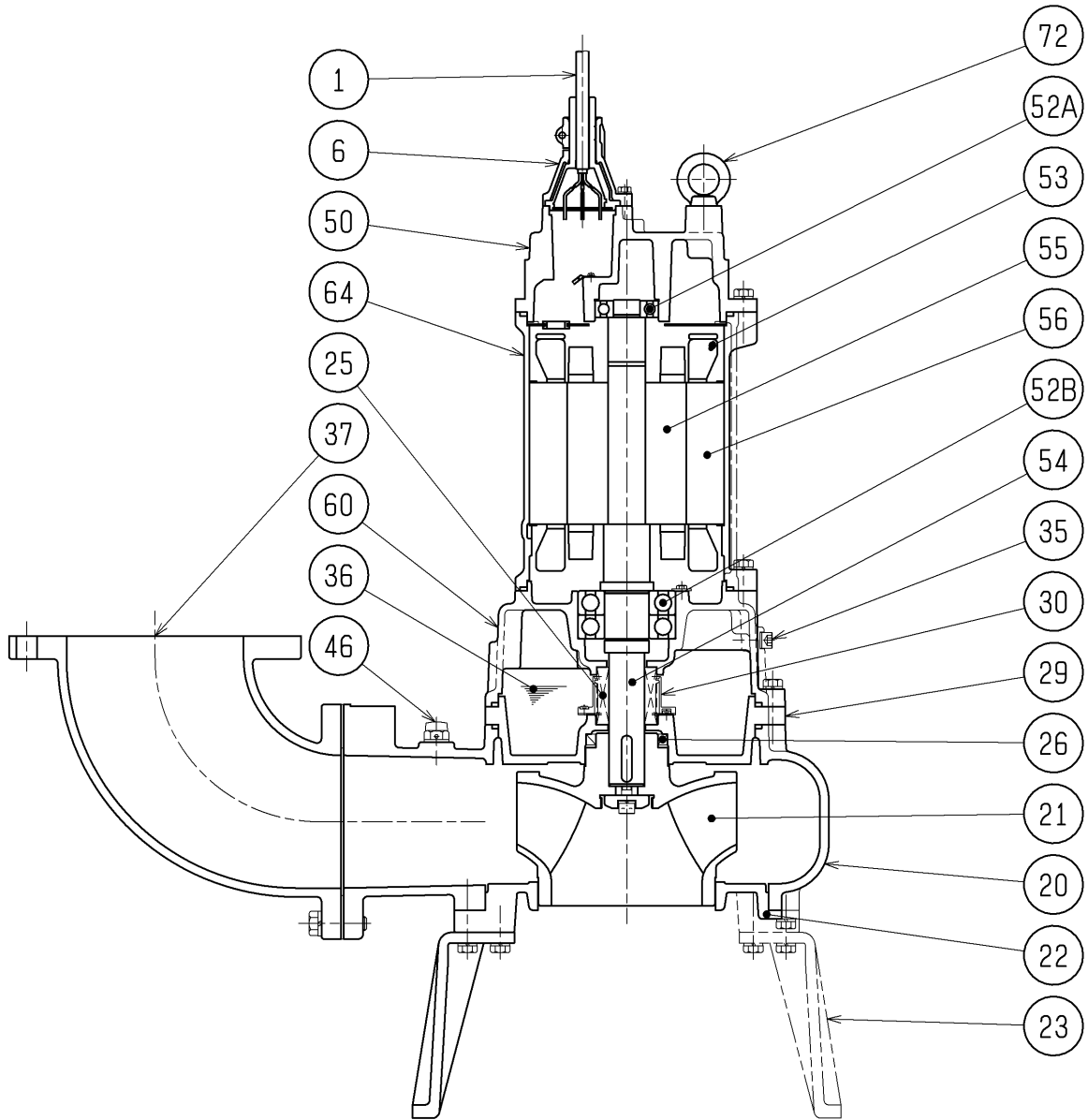

REQ. SPECIFICATION

No.	DESCRIPTION	Q'TY	MATERIAL / NOTE	No.	DESCRIPTION	Q'TY	MATERIAL / NOTE
1	Cabtyre Cable	2	Chloroprene Sheath (For the Power)	46	Air Release Valve	1	Nylon
		1	PVC Sheath (For the Control)	50	Motor Bracket	1	Gray Iron Casting
6	Stuffing Box	2	Gray Iron Casting	52A	Upper Bearing	1	6306ZZC3
20	Pump Casing	1	Gray Iron Casting	52B	Lower Bearing	2	6310ZZC3
21	Impeller	1	Gray Iron Casting	53	Motor Protector	1	
22	Suction Cover	1	Gray Iron Casting	54	Shaft	1	Stainless Steel 420J2
23	Stand	3	Ductile Iron Casting	55	Rotor	1	
25	Mechanical Seal	1	H-40X	56	Stator	1	
26	Oil Seal	1	TC709212	60	Bearing Housing	1	Gray Iron Casting
29	Oil Casing	1	Gray Iron Casting	64	Motor Frame	1	Gray Iron Casting
30	Oil Lifter	1	Plastic	72	Eyebolt	2	Structure Steel
35	Oil Plug	2	Stainless Steel 304				
36	Lubricant		Turbine Oil (ISO VG32)				
37	Discharge Bend	1	Gray Iron Casting				