

NO. A-07518-3

# PUMP PERFORMANCE CURVES

TYPE Submersible Sewage & Wastewater Pump	MODEL 100B43.7 -52 TOS100B43.7 -52	FREQUENCY 50 Hz
---	--	--------------------

CUSTOMER'S NAME \_\_\_\_\_

EQUIPMENT TITLE \_\_\_\_\_ NO. \_\_\_\_\_

	STANDARD SPECIFICATIONS	REQUIRED SPECIFICATIONS
DISCHARGE BORE	100 mm	mm
TOTAL HEAD	MAX. 16.4 m	m
CAPACITY	MAX. 2.0 m <sup>3</sup> /min	m <sup>3</sup> /min
MOTOR OUTPUT	3.7 kW	kW
PHASE × VOLTAGE	3 φ × V	φ × V
CURRENT	A	A
POLES / REVOLUTION	4 P / S. S. 1500 min <sup>-1</sup>	P / min <sup>-1</sup>
STARTING METHOD	DIRECT ON LINE	
INSULATION CLASS	E	

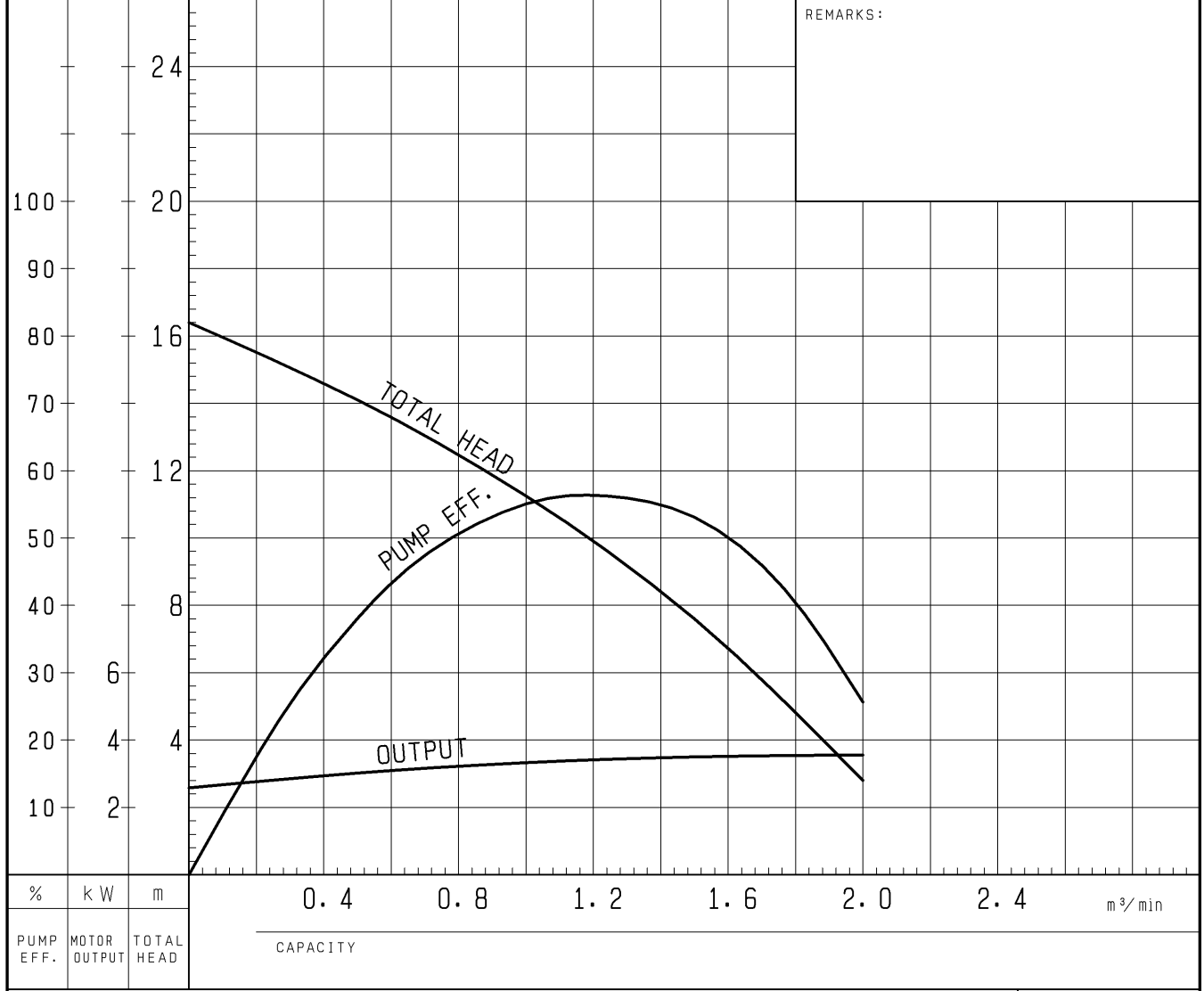

TSURUMI MFG. CO., LTD.

DIMENSION DRAWING		No.	No.	A-16067-5
TYPE	Submersible Sewage & Wastewater Pump	MODEL	80/100B42.2 -52/62 80/100B43.7 -52/62	

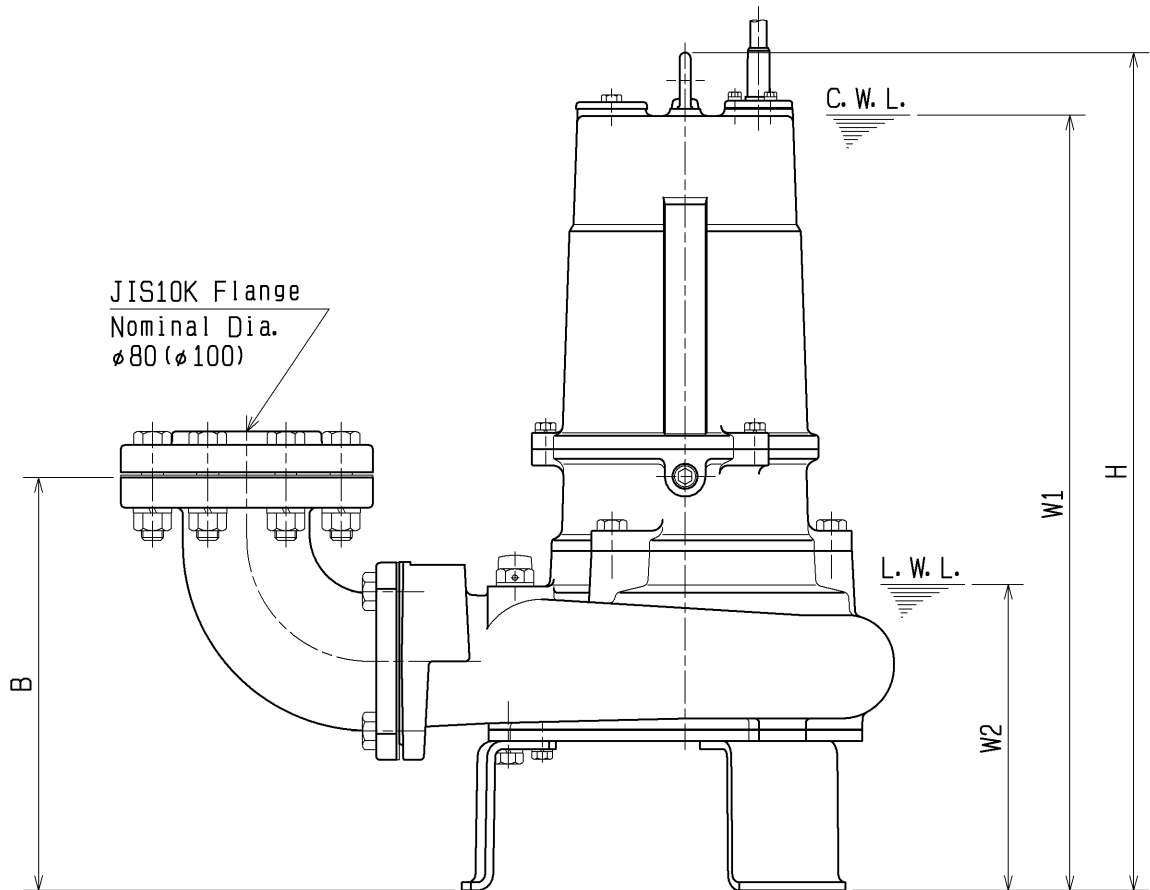
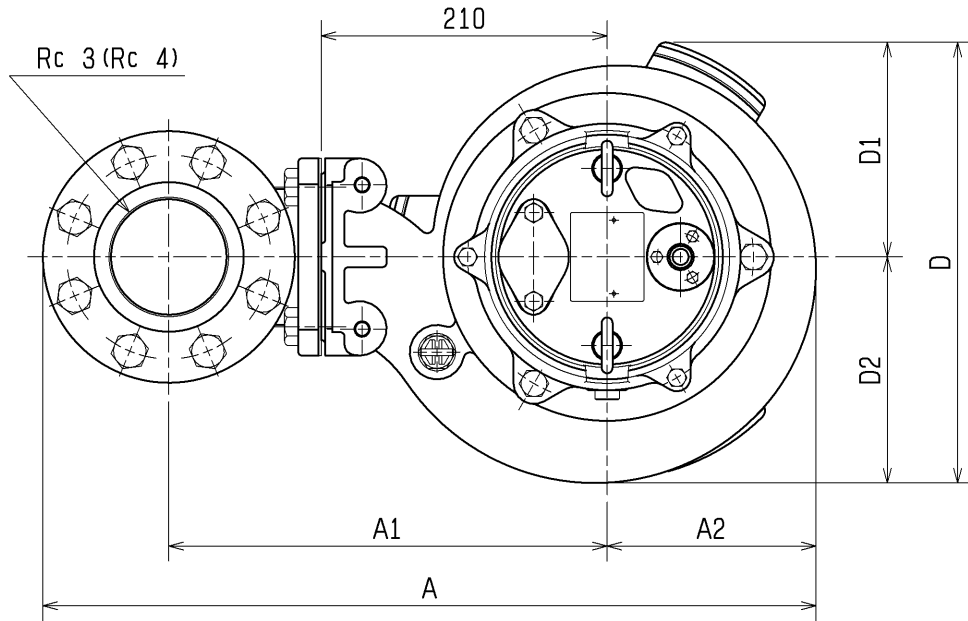

The Figure in ( ) shows the dimensions of discharge Bore at Nominal Dia  $\phi 100$ .

C. W. L. :Continuous running Water Level  
L. W. L. :Lowest running Water Level

\*excluding cable

MODEL	A	A1	A2	B	D	D1	D2	W1	W2	H	Approximate Weight (kg)
80/100B42.2-52/62	568 (596)	322 (337)	154	304 (329)	324	158	166	570	225	616	68kg
80/100B43.7-52/62	574 (601)	322 (337)	159	309 (334)	333	158	175	645	235	690	84kg

<b>SECTIONAL DRAWING</b>		No.	No.	A-19419-4
TYPE	Submersible Sewage & Wastewater Pump	MODEL	80/100B42.2 -52/62 80/100B43.7 -52/62	

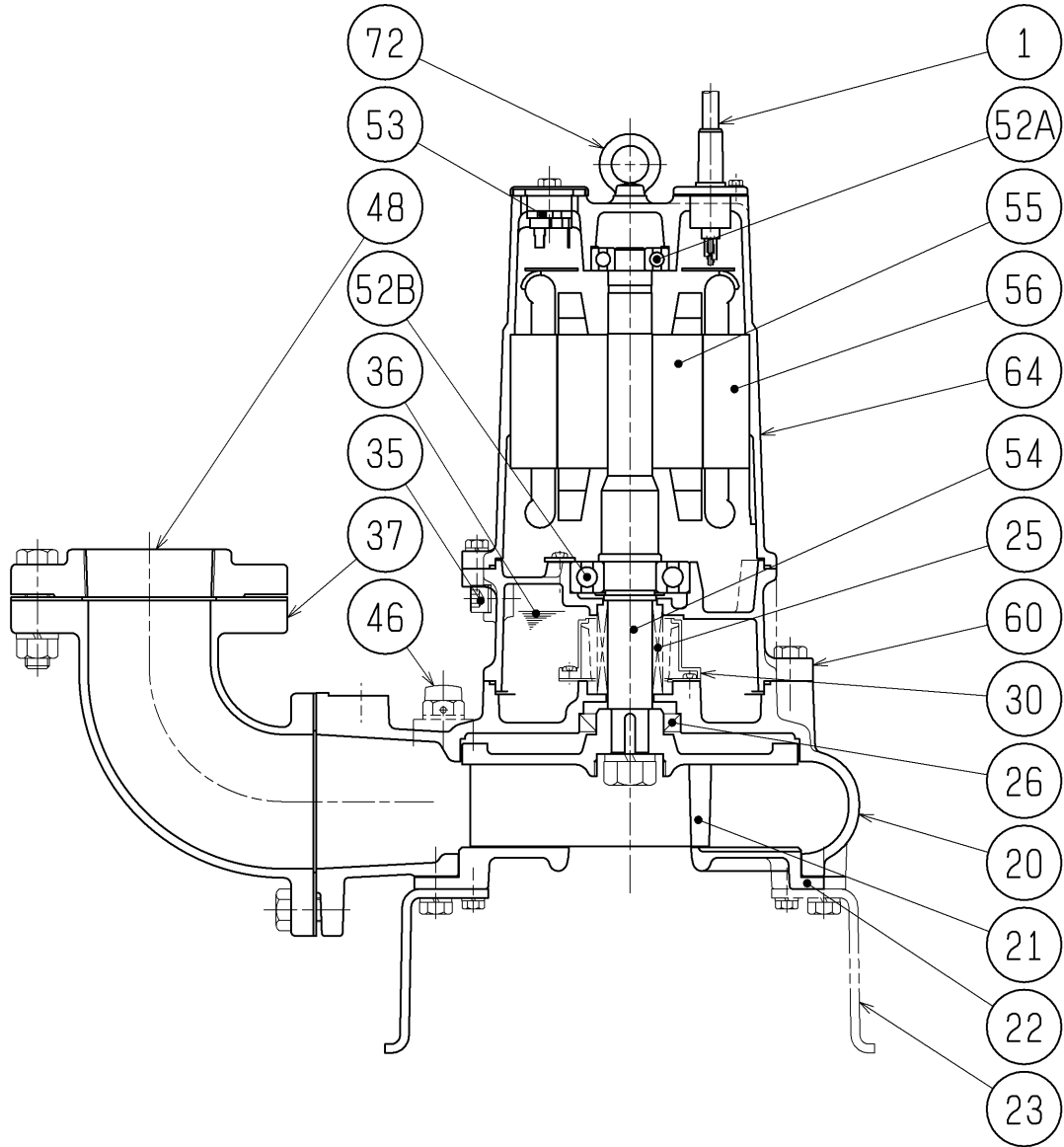

	2.2kW	3.7kW
※1	H-30A	H-35A
※2	TC456812	TC507212
※3	6307ZZC3	6309ZZC3

※4 the wetted part

REQ. SPECIFICATION		

No.	DESCRIPTION	QTY	MATERIAL / NOTE	No.	DESCRIPTION	QTY	MATERIAL / NOTE
1	Cable	1	PVC Sheath	48	Screwed Flange	1	Gray Iron Casting
20	Pump Casing	1	Gray Iron Casting	52A	Upper Bearing	1	6304ZZC3
21	Impeller	1	Gray Iron Casting	52B	Lower Bearing	1	※3
22	Suction Cover	1	Gray Iron Casting	53	Motor Protector	1	
23	Stand	3	Steel Plate	54	Shaft	1	Stainless Steel 420J2(※4)
25	Mechanical Seal	1	※1	55	Rotor	1	
26	Oil Seal	1	※2	56	Stator	1	
30	Oil Lifter	1	Plastic	60	Bearing Housing	1	Gray Iron Casting
35	Oil Plug	1	Stainless Steel 304	64	Motor Frame	1	Gray Iron Casting
36	Lubricant		Turbine Oil (ISO VG32)	72	Eye Bolt	2	Stainless Steel 304
37	Discharge Bend	1	Gray Iron Casting				
46	Air Release Valve	1	Nylon				